

**WORLD CLASS 3000
OXYGEN ANALYZER
WITH HPS HEATER POWER
SUPPLY FIELD MODULE
(FOR USE WITH EXISTING SIGNAL
CONDITIONING ELECTRONICS)**

Instruction Bulletin IB-106-300NE Rev. 3.4

World Class 3000 Probe	HPS 3000
Part No. _____	Part No. _____
Serial No. _____	Serial No. _____
Order No. _____	Order No. _____

ROSEMOUNT[®] ANALYTICAL

FISHER-ROSEMOUNT™ Managing The Process Better™

HIGHLIGHTS OF CHANGES

Effective October, 1995 Rev. 3

PAGE	SUMMARY
1-1	Updated art to reflect new probe configuration.
1-3	Updated art to reflect new probe configuration.
1-4	Updated art to reflect new probe configuration.
2-1	Updated installation procedure to include optional ceramic diffusor and vee deflector.
2-2	Updated art and dimensions to reflect new probe configurations.
2-3	Updated art and dimensions to reflect new probe configurations.
2-8	Updated art to reflect new probe configuration.

Effective June, 1996 Rev. 3.1

PAGE	SUMMARY
1-3	Added ambient air note.
2-3	Updated Probe Installation, Figure 2-1, sheets 1 and 2 of 5.

Effective January, 1997 Rev. 3.2

PAGE	SUMMARY
iii	Added "Safety instructions for the wiring and installation of this apparatus".
2-1	Added one WARNING to read new safety instructions and another WARNING regarding protective covers and grounds.
2-7	Added WARNING regarding protective covers and grounds and added NOTE regarding HPS fuse locations and specifications.
2-10	Added NOTE regarding HPS fuse specifications to Figure 2-7.
3-1	Added WARNING regarding protective covers and grounds.
4-1	Added WARNING regarding protective covers and grounds.
I-1	Added fuses to index listing.

HIGHLIGHTS OF CHANGES (continued)

Effective May, 1997 Rev. 3.3

PAGE	SUMMARY
iii-xv	Added foreign language safety sheets.

Effective February, 1998 Rev. 3.4

PAGE	SUMMARY
2-2	Figure 2-1. Changed calibration gas tube dimensions.

ROSEMOUNT WARRANTY

Rosemount warrants that the equipment manufactured and sold by it will, upon shipment, be free of defects in workmanship or material. Should any failure to conform to this warranty become apparent during a period of one year after the date of shipment, Rosemount shall, upon prompt written notice from the purchaser, correct such nonconformity by repair or replacement, F.O.B. factory of the defective part or parts. Correction in the manner provided above shall constitute a fulfillment of all liabilities of Rosemount with respect to the quality of the equipment.

THE FOREGOING WARRANTY IS EXCLUSIVE AND IN LIEU OF ALL OTHER WARRANTIES OF QUALITY WHETHER WRITTEN, ORAL, OR IMPLIED (INCLUDING ANY WARRANTY OF MERCHANTABILITY OF FITNESS FOR PURPOSE).

The remedy(ies) provided above shall be purchaser's sole remedy(ies) for any failure of Rosemount to comply with the warranty provisions, whether claims by the purchaser are based in contract or in tort (including negligence).

Rosemount does not warrant equipment against normal deterioration due to environment. Factors such as corrosive gases and solid particulates can be detrimental and can create the need for repair or replacement as part of normal wear and tear during the warranty period.

Equipment supplied by Rosemount Analytical Inc. but not manufactured by it will be subject to the same warranty as is extended to Rosemount by the original manufacturer.

At the time of installation it is important that the required services are supplied to the system and that the electronic controller is set up at least to the point where it is controlling the sensor heater. This will ensure, that should there be a delay between installation and full commissioning, that the sensor being supplied with ac power and reference air will not be subjected to component deterioration.

Experience shows that systems installed and not supplied with services can be damaged either by the process or by the external environment, and Rosemount will not accept any responsibility for this consequence.



If the HPS 3000 and World Class 3000 probe are used with any of the following model electronics; 218, 225, 218A, and TC200, read appropriate set point adjustment in Instruction Bulletin (IB) 106-300NE to prevent damage to the World Class 3000 probe.

PURPOSE

The purpose of this manual is to provide a comprehensive understanding of the World Class 3000 Oxygen Analyzer, components, functions, installation, and maintenance.

This manual is designed to provide information about the World Class 3000 Oxygen Analyzer. We recommend that you thoroughly familiarize yourself with the Overview and Installation sections before installing your emissions monitor.

The overview presents the basic principles of the oxygen analyzer along with its performance characteristics and components. The remaining sections contain detailed procedures and information necessary for installation and servicing of the oxygen analyzer.

Before contacting Rosemount concerning any questions, first consult this manual. It describes most situations encountered in your equipment's operation and details necessary action.

DEFINITIONS

The following definitions apply to WARNINGS, CAUTIONS, and NOTES found throughout this publication.

WARNING

Highlights an operation or maintenance procedure, practice, condition, statement, etc. If not strictly observed, could result in injury, death, or long-term health hazards of personnel.

CAUTION

Highlights an operation or maintenance procedure, practice, condition, statement, etc. If not strictly observed, could result in damage to or destruction of equipment, or loss of effectiveness.

NOTE

Highlights an essential operating procedure, condition, or statement.



NOTE TO USERS

The number in the lower right corner of the illustrations in this publication is a manual illustration number. It is not a part number, and is not related to the illustration in any technical manner.

IMPORTANT

SAFETY INSTRUCTIONS FOR THE WIRING AND INSTALLATION OF THIS APPARATUS



The following safety instructions apply specifically to all EU member states. They should be strictly adhered to in order to assure compliance with the Low Voltage Directive. Non-EU states should also comply with the following unless superseded by local or National Standards.

1. Adequate earth connections should be made to all earthing points, internal and external, where provided.
2. After installation or troubleshooting, all safety covers and safety grounds must be replaced. The integrity of all earth terminals must be maintained at all times.
3. Mains supply cords should comply with the requirements of IEC227 or IEC245.
4. All wiring shall be suitable for use in an ambient temperature of greater than 75°C.
5. All cable glands used should be of such internal dimensions as to provide adequate cable anchorage.
6. To ensure safe operation of this equipment, connection to the mains supply should only be made through a circuit breaker which will disconnect all circuits carrying conductors during a fault situation. The circuit breaker may also include a mechanically operated isolating switch. If not, then another means of disconnecting the equipment from the supply must be provided and clearly marked as such. Circuit breakers or switches must comply with a recognized standard such as IEC947. All wiring must conform with any local standards.
7. Where equipment or covers are marked with the symbol to the right, hazardous voltages are likely to be present beneath. These covers should only be removed when power is removed from the equipment — and then only by trained service personnel.

8. Where equipment or covers are marked with the symbol to the right, there is a danger from hot surfaces beneath. These covers should only be removed by trained service personnel when power is removed from the equipment. Certain surfaces may remain hot to the touch.

9. Where equipment or covers are marked with the symbol to the right, refer to the Operator Manual for instructions.

10. All graphical symbols used in this product are from one or more of the following standards: EN61010-1, IEC417, and ISO3864.

BELANGRIJK

Veiligheidsvoorschriften voor de aansluiting en installatie van dit toestel.



De hierna volgende veiligheidsvoorschriften zijn vooral bedoeld voor de EU lidstaten. Hier moet aan gehouden worden om de onderworpenheid aan de Laag Spannings Richtlijn (Low Voltage Directive) te verzekeren. Niet EU staten zouden deze richtlijnen moeten volgen tenzij zij reeds achterhaald zouden zijn door plaatselijke of nationale voorschriften.

1. Degelijke aardingsaansluitingen moeten gemaakt worden naar alle voorziene aardpunten, intern en extern.
2. Na installatie of controle moeten alle veiligheidsdeksels en -aarding terug geplaatst worden. Ten alle tijde moet de betrouwbaarheid van de aarding behouden blijven.
3. Voedingskabels moeten onderworpen zijn aan de IEC227 of de IEC245 voorschriften.
4. Alle bekabeling moet geschikt zijn voor het gebruik in omgevingstemperaturen, hoger dan 75°C.
5. Alle wartels moeten zo gedimensioneerd zijn dat een degelijke kabel bevestiging verzekerd is.
6. Om de veilige werking van dit toestel te verzekeren, moet de voeding door een stroomonderbreker gevoerd worden (min 10A) welke alle draden van de voeding moet onderbreken. De stroomonderbreker mag een mechanische schakelaar bevatten. Zoniet moet een andere mogelijkheid bestaan om de voedingsspanning van het toestel te halen en ook duidelijk zo zijn aangegeven. Stroomonderbrekers of schakelaars moeten onderworpen zijn aan een erkende standaard zoals IEC947.
7. Waar toestellen of deksels aangegeven staan met het symbool is er meestal hoogspanning aanwezig. Deze deksels mogen enkel verwijderd worden nadat de voedingsspanning werd afgelegd en enkel door getraind onderhoudspersoneel.
8. Waar toestellen of deksels aangegeven staan met het symbool is er gevaar voor hete oppervlakken. Deze deksels mogen enkel verwijderd worden door getraind onderhoudspersoneel nadat de voedingsspanning verwijderd werd. Sommige oppervlakken kunnen 45 minuten later nog steeds heet aanvoelen.
9. Waar toestellen of deksels aangegeven staan met het symbool gelieve het handboek te raadplegen.
10. Alle grafische symbolen gebruikt in dit produkt, zijn afkomstig uit een of meer van devolgende standaards; EN61010-1, IEC417 en ISO3864.

VIGTIGT

Sikkerhedsinstruktion for tilslutning og installation af dette udstyr.



Følgende sikkerhedsinstruktioner gælder specifikt i alle EU-medlemslande. Instruktionerne skal nøje følges for overholdelse af Lavspændingsdirektivet og bør også følges i ikke EU-lande medmindre andet er specificeret af lokale eller nationale standarder.

1. Passende jordforbindelser skal tilsluttes alle jordklemmer, interne og eksterne, hvor disse forefindes.
2. Efter installation eller fejlfinding skal alle sikkerhedsdæksler og jordforbindelser reetableres.
3. Forsyningskabler skal opfylde krav specificeret i IEC227 eller IEC245.
4. Alle ledningstilslutninger skal være konstrueret til omgivelsestemperatur højere end 75° C.
5. Alle benyttede kabelforskruninger skal have en intern dimension, så passende kabelafkastning kan etableres.
6. For opnåelse af sikker drift og betjening skal der skabes beskyttelse mod indirekte berøring gennem afbryder (min. 10A), som vil afbryde alle kredsløb med elektriske ledere i fejlsituation. Afbryderen skal indholde en mekanisk betjent kontakt. Hvis ikke skal anden form for afbryder mellem forsyning og udstyr benyttes og mærkes som sådan. Afbrydere eller kontakter skal overholde en kendt standard som IEC947.
7. Hvor udstyr eller dæksler er mærket med dette symbol, er farlige spændinger normalt forekommende bagved. Disse dæksler bør kun afmonteres, når forsyningsspændingen er frakoblet - og da kun af instrueret servicepersonale. 
8. Hvor udstyr eller dæksler er mærket med dette symbol, forefindes meget varme overflader bagved. Disse dæksler bør kun afmonteres af instrueret servicepersonale, når forsyningsspænding er frakoblet. Visse overflader vil stadig være for varme at berøre i op til 45 minutter efter frakobling. 
9. Hvor udstyr eller dæksler er mærket med dette symbol, se da i betjeningsmanual for instruktion. 
10. Alle benyttede grafiske symboler i dette udstyr findes i én eller flere af følgende standarder:- EN61010-1, IEC417 & ISO3864.

BELANGRIJK

Veiligheidsinstructies voor de bedrading en installatie van dit apparaat.



Voor alle EU lidstaten zijn de volgende veiligheidsinstructies van toepassing. Om aan de geldende richtlijnen voor laagspanning te voldoen dient men zich hieraan strikt te houden. Ook niet EU lidstaten dienen zich aan het volgende te houden, tenzij de lokale wetgeving anders voorschrijft.

1. Alle voorziene interne- en externe aardaansluitingen dienen op adequate wijze aangesloten te worden.
2. Na installatie, onderhouds- of reparatie werkzaamheden dienen alle beschermdeksels /kappen en aardingen om reden van veiligheid weer aangebracht te worden.
3. Voedingskabels dienen te voldoen aan de vereisten van de normen IEC 227 of IEC 245.
4. Alle bedrading dient geschikt te zijn voor gebruik bij een omgevings temperatuur boven 75°C.
5. Alle gebruikte kabelwartels dienen dusdanige inwendige afmetingen te hebben dat een adequate verankering van de kabel wordt verkregen.
6. Om een veilige werking van de apparatuur te waarborgen dient de voeding uitsluitend plaats te vinden via een meerpole automatische zekering (min.10A) die **alle** spanningvoerende geleiders verbreekt indien een foutconditie optreedt. Deze automatische zekering mag ook voorzien zijn van een mechanisch bediende schakelaar. Bij het ontbreken van deze voorziening dient een andere als zodanig duidelijk aangegeven mogelijkheid aanwezig te zijn om de spanning van de apparatuur af te schakelen. Zekeringen en schakelaars dienen te voldoen aan een erkende standaard zoals IEC 947.
7. Waar de apparatuur of de beschermdeksels/kappen gemarkeerd zijn met het volgende symbool, kunnen zich hieronder spanning voerende delen bevinden die gevaar op kunnen leveren. Deze beschermdeksels/kappen mogen uitsluitend verwijderd worden door getraind personeel als de spanning is afgeschakeld. 
8. Waar de apparatuur of de beschermdeksels/kappen gemarkeerd zijn met het volgende symbool, kunnen zich hieronder hete oppervlakken of onderdelen bevinden. Bepaalde delen kunnen mogelijk na 45 min. nog te heet zijn om aan te raken. 
9. Waar de apparatuur of de beschermdeksels/kappen gemarkeerd zijn met het volgende symbool, dient men de bedieningshandleiding te raadplegen. 
10. Alle grafische symbolen gebruikt bij dit produkt zijn volgens een of meer van de volgende standaarden: EN 61010-1, IEC 417 & ISO 3864.

TÄRKEÄÄ

Turvallisuusohje, jota on noudatettava tämän laitteen asentamisessa ja kaapeloinnissa.



Seuraavat ohjeet pätevät erityisesti EU:n jäsenvaltioissa. Niitä täytyy ehdottomasti noudattaa jotta täytettäisiin EU:n matalajännittdirektiivin (Low Voltage Directive) yhteensopivuus. Myös EU:hun kuulumattomien valtioiden tulee noudattaa tätä ohjetta, elleivät kansalliset standardit estä sitä.

1. Riittävät maadoituskytkennät on tehtävä kaikkiin maadoituspisteisiin, sisäisiin ja ulkoisiin.
2. Asennuksen ja vianetsinnän jälkeen on kaikki suojat ja suojamaat asennettava takaisin paikoilleen. Maadoitusliittimen kunnollinen toiminta täytyy aina ylläpitää.
3. Jännitesyöttöjohtimien täytyy täyttää IEC227 ja IEC245 vaatimukset.
4. Kaikkien johdotuksien tulee toimia $>75^{\circ}\text{C}$ lämpötiloissa.
5. Kaikkien läpivientiholkkien sisähalkaisijan täytyy olla sellainen että kaapeli lukkiutuu kunnolla kiinni.
6. Turvallisen toiminnan varmistamiseksi täytyy jännitesyöttö varustaa turvakytkimellä (min 10A), joka kytkee irti kaikki jännitesyöttöjohtimet vikatilanteessa. Suojaan täytyy myös sisältyä mekaaninen erotuskytkin. Jos ei, niin jännitesyöttö on pystyttävä katkaisemaan muilla keinoilla ja merkittävä siten että se tunnustetaan sellaiseksi. Turvakytkimien tai katkaisimien täytyy täyttää IEC947 standardin vaatimukset näkyvyydestä.
7. Mikäli laite tai kosketussuoja on merkitty tällä merkillä on merkinnän takana tai alla hengenvaarallisen suuruinen jännite. Suojaa ei saa poistaa jänniteen ollessa kytkettynä laitteeseen ja poistamisen saa suorittaa vain alan asiantuntija. 
8. Mikäli laite tai kosketussuoja on merkitty tällä merkillä on merkinnän takana tai alla kuuma pinta. Suojaa saa poistaa vain alan asiantuntija kun jännitesyöttö on katkaistu. Tällainen pinta voi säilyä kosketuskuumana jopa 45 minuuttia. 
9. Mikäli laite tai kosketussuoja on merkitty tällä merkillä katso lisäohjeita käyttöohjekirjasta 
10. Kaikki tässä tuotteessa käytetyt graafiset symbolit ovat yhdestä tai useammasta seuraavista standardeista: EN61010-1, IEC417 & ISO3864.

IMPORTANT

Consignes de sécurité concernant le raccordement et l'installation de cet appareil.



Les consignes de sécurité ci-dessous s'adressent particulièrement à tous les états membres de la communauté européenne. Elles doivent être strictement appliquées afin de satisfaire aux directives concernant la basse tension. Les états non membres de la communauté européenne doivent également appliquer ces consignes sauf si elles sont en contradiction avec les standards locaux ou nationaux.

1. Un raccordement adéquate à la terre doit être effectuée à chaque borne de mise à la terre, interne et externe.
2. Après installation ou dépannage, tous les capots de protection et toutes les prises de terre doivent être remis en place, toutes les prises de terre doivent être respectées en permanence.
3. Les câbles d'alimentation électrique doivent être conformes aux normes IEC227 ou IEC245
4. Tous les raccordements doivent pouvoir supporter une température ambiante supérieure à 75°C.
5. Tous les presse-étoupes utilisés doivent avoir un diamètre interne en rapport avec les câbles afin d'assurer un serrage correct sur ces derniers.
6. Afin de garantir la sécurité du fonctionnement de cet appareil, le raccordement à l'alimentation électrique doit être réalisé exclusivement au travers d'un disjoncteur (minimum 10A.) isolant tous les conducteurs en cas d'anomalie. Ce disjoncteur doit également pouvoir être actionné manuellement, de façon mécanique. Dans le cas contraire, un autre système doit être mis en place afin de pouvoir isoler l'appareil et doit être signalisé comme tel. Disjoncteurs et interrupteurs doivent être conformes à une norme reconnue telle IEC947.
7. Lorsque les équipements ou les capots affichent le symbole suivant, cela signifie que des tensions dangereuses sont présentes. Ces capots ne doivent être démontés que lorsque l'alimentation est coupée, et uniquement par un personnel compétent.

8. Lorsque les équipements ou les capots affichent le symbole suivant, cela signifie que des surfaces dangereusement chaudes sont présentes. Ces capots ne doivent être démontés que lorsque l'alimentation est coupée, et uniquement par un personnel compétent. Certaines surfaces peuvent rester chaudes jusqu'à 45 mn.

9. Lorsque les équipements ou les capots affichent le symbole suivant, se reporter au manuel d'instructions.

10. Tous les symboles graphiques utilisés dans ce produit sont conformes à un ou plusieurs des standards suivants: EN61010-1, IEC417 & ISO3864.

Wichtig

Sicherheitshinweise für den Anschluß und die Installation dieser Geräte.



Die folgenden Sicherheitshinweise sind in allen Mitgliederstaaten der europäischen Gemeinschaft gültig. Sie müssen strikt eingehalten werden, um der Niederspannungsrichtlinie zu genügen. Nichtmitgliedstaaten der europäischen Gemeinschaft sollten die national gültigen Normen und Richtlinien einhalten.

1. Alle intern und extern vorgesehenen Erdungen der Geräte müssen ausgeführt werden.
2. Nach Installation, Reparatur oder sonstigen Eingriffen in das Gerät müssen alle Sicherheitsabdeckungen und Erdungen wieder installiert werden. Die Funktion aller Erdverbindungen darf zu keinem Zeitpunkt gestört sein.
3. Die Netzspannungsversorgung muß den Anforderungen der IEC227 oder IEC245 genügen.
4. Alle Verdrahtungen sollten mindestens bis 75 °C ihre Funktion dauerhaft erfüllen.
5. Alle Kabeldurchführungen und Kabelverschraubungen sollten in Ihrer Dimensionierung so gewählt werden, daß diese eine sichere Verkabelung des Gerätes ermöglichen.
6. Um eine sichere Funktion des Gerätes zu gewährleisten, muß die Spannungsversorgung über mindestens 10 A abgesichert sein. Im Fehlerfall muß dadurch gewährleistet sein, daß die Spannungsversorgung zum Gerät bzw. zu den Geräten unterbrochen wird. Ein mechanischer Schutzschalter kann in dieses System integriert werden. Falls eine derartige Vorrichtung nicht vorhanden ist, muß eine andere Möglichkeit zur Unterbrechung der Spannungszufuhr gewährleistet werden mit Hinweisen deutlich gekennzeichnet werden. Ein solcher Mechanismus zur Spannungsunterbrechung muß mit den Normen und Richtlinien für die allgemeine Installation von Elektrogeräten, wie zum Beispiel der IEC947, übereinstimmen.
7. Mit dem Symbol sind Geräte oder Abdeckungen gekennzeichnet, die eine gefährliche (Netzspannung) Spannung führen. Die Abdeckungen dürfen nur entfernt werden, wenn die Versorgungsspannung unterbrochen wurde. Nur geschultes Personal darf an diesen Geräten Arbeiten ausführen. 
8. Mit dem Symbol sind Geräte oder Abdeckungen gekennzeichnet, in bzw. unter denen heiße Teile vorhanden sind. Die Abdeckungen dürfen nur entfernt werden, wenn die Versorgungsspannung unterbrochen wurde. Nur geschultes Personal darf an diesen Geräten Arbeiten ausführen. Bis 45 Minuten nach dem Unterbrechen der Netzzufuhr können derartig Teile noch über eine erhöhte Temperatur verfügen. 
9. Mit dem Symbol sind Geräte oder Abdeckungen gekennzeichnet, bei denen vor dem Eingriff die entsprechenden Kapitel im Handbuch sorgfältig durchgelesen werden müssen. 
10. Alle in diesem Gerät verwendeten graphischen Symbole entspringen einem oder mehreren der nachfolgend aufgeführten Standards: EN61010-1, IEC417 & ISO3864.

IMPORTANTE

Norme di sicurezza per il cablaggio e l'installazione dello strumento.



Le seguenti norme di sicurezza si applicano specificatamente agli stati membri dell'Unione Europea, la cui stretta osservanza è richiesta per garantire conformità alla Direttiva del Basso Voltaggio. Esse si applicano anche agli stati non appartenenti all'Unione Europea, salvo quanto disposto dalle vigenti normative locali o nazionali.

1. Collegamenti di terra idonei devono essere eseguiti per tutti i punti di messa a terra interni ed esterni, dove previsti.
2. Dopo l'installazione o la localizzazione dei guasti, assicurarsi che tutti i coperchi di protezione siano stati collocati e le messa a terra siano collegate. L'integrità di ciascun morsetto di terra deve essere costantemente garantita.
3. I cavi di alimentazione della rete devono essere secondo disposizioni IEC227 o IEC245.
4. L'intero impianto elettrico deve essere adatto per uso in ambiente con temperature superiore a 75°C.
5. Le dimensioni di tutti i connettori dei cavi utilizzati devono essere tali da consentire un adeguato ancoraggio al cavo.
6. Per garantire un sicuro funzionamento dello strumento il collegamento alla rete di alimentazione principale dovrà essere eseguita tramite interruttore automatico (min.10A), in grado di disattivare tutti i conduttori di circuito in caso di guasto. Tale interruttore dovrà inoltre prevedere un sezionatore manuale o altro dispositivo di interruzione dell'alimentazione, chiaramente identificabile. Gli interruttori dovranno essere conformi agli standard riconosciuti, quali IEC947.
7. Il simbolo riportato sullo strumento o sui coperchi di protezione indica probabile presenza di elevati voltaggi. Tali coperchi di protezione devono essere rimossi esclusivamente da personale qualificato, dopo aver tolto alimentazione allo strumento. 
8. Il simbolo riportato sullo strumento o sui coperchi di protezione indica rischio di contatto con superfici ad alta temperatura. Tali coperchi di protezione devono essere rimossi esclusivamente da personale qualificato, dopo aver tolto alimentazione allo strumento. Alcune superfici possono mantenere temperature elevate per oltre 45 minuti. 
9. Se lo strumento o il coperchio di protezione riportano il simbolo, fare riferimento alle istruzioni del manuale Operatore. 
10. Tutti i simboli grafici utilizzati in questo prodotto sono previsti da uno o più dei seguenti standard: EN61010-1, IEC417 e ISO3864.

VIKTIG

Sikkerhetsinstruks for tilkobling og installasjon av dette utstyret.



Følgende sikkerhetsinstruksjoner gjelder spesifikt alle EU medlemsland og land med i EØS-avtalen. Instruksjonene skal følges nøye slik at installasjonen blir i henhold til lavspenningsdirektivet. Den bør også følges i andre land, med mindre annet er spesifisert av lokale- eller nasjonale standarder.

1. Passende jordforbindelser må tilkobles alle jordingspunkter, interne og eksterne hvor disse forefinnes.
2. Etter installasjon eller feilsøking skal alle sikkerhetsdeksler og jordforbindelser reetableres. Jordingsforbindelsene må alltid holdes i god stand.
3. Kabler fra spenningsforsyning skal oppfylle kravene spesifisert i IEC227 eller IEC245.
4. Alle ledningsforbindelser skal være konstruert for en omgivelsestemperatur høyere en 750C.
5. Alle kabelforskruvninger som benyttes skal ha en indre dimensjon slik at tilstrekkelig avlastning oppnåes.
6. For å oppnå sikker drift og betjening skal forbindelsen til spenningsforsyningen bare skje gjennom en strømbryter (minimum 10A) som vil bryte spenningsforsyningen til alle elektriske kretser ved en feilsituasjon. Strømbryteren kan også inneholde en mekanisk operert bryter for å isolere instrumentet fra spenningsforsyningen. Dersom det ikke er en mekanisk operert bryter installert, må det være en annen måte å isolere utstyret fra spenningsforsyningen, og denne måten må være tydelig merket. Krets-brytere eller kontakter skal oppfylle kravene i en anerkjent standard av typen IEC947 eller tilsvarende.
7. Der hvor utstyr eller deksler er merket med symbol for farlig spenning, er det sannsynlig at disse er tilstede bak dekslet. Disse dekslene må bare fjernes når spenningsforsyning er frakoblet utstyret, og da bare av trenet servicepersonell. 
8. Der hvor utstyr eller deksler er merket med symbol for meget varm overflate, er det sannsynlig at disse er tilstede bak dekslet. Disse dekslene må bare fjernes når spenningsforsyning er frakoblet utstyret, og da bare av trenet servicepersonell. Noen overflater kan være for varme til å berøres i opp til 45 minutter etter spenningsforsyning frakoblet. 
9. Der hvor utstyret eller deksler er merket med symbol, vennligst referer til instruksjonsmanualen for instruksjer. 
10. Alle grafiske symboler brukt i dette produktet er fra en eller flere av følgende standarder: EN61010-1, IEC417 & ISO3864.

IMPORTANTE

Instruções de segurança para ligação e instalação deste aparelho.



As seguintes instruções de segurança aplicam-se especificamente a todos os estados membros da UE. Devem ser observadas rigidamente por forma a garantir o cumprimento da Directiva sobre Baixa Tensão. Relativamente aos estados que não pertençam à UE, deverão cumprir igualmente a referida directiva, exceptuando os casos em que a legislação local a tiver substituído.

1. Devem ser feitas ligações de terra apropriadas a todos os pontos de terra, internos ou externos.
2. Após a instalação ou eventual reparação, devem ser recolocadas todas as tampas de segurança e terras de protecção. Deve manter-se sempre a integridade de todos os terminais de terra.
3. Os cabos de alimentação eléctrica devem obedecer às exigências das normas IEC227 ou IEC245.
4. Os cabos e fios utilizados nas ligações eléctricas devem ser adequados para utilização a uma temperatura ambiente até 75° C.
5. As dimensões internas dos buçins dos cabos devem ser adequadas a uma boa fixação dos cabos.
6. Para assegurar um funcionamento seguro deste equipamento, a ligação ao cabo de alimentação eléctrica deve ser feita através de um disjuntor (min. 10A) que desligará todos os condutores de circuitos durante uma avaria. O disjuntor poderá também conter um interruptor de isolamento accionado manualmente. Caso contrário, deverá ser instalado qualquer outro meio para desligar o equipamento da energia eléctrica, devendo ser assinalado convenientemente. Os disjuntores ou interruptores devem obedecer a uma norma reconhecida, tipo IEC947.
7. Sempre que o equipamento ou as tampas contiverem o símbolo, é provável a existência de tensões perigosas. Estas tampas só devem ser retiradas quando a energia eléctrica tiver sido desligada e por Pessoal da Assistência devidamente treinado. 
8. Sempre que o equipamento ou as tampas contiverem o símbolo, há perigo de existência de superfícies quentes. Estas tampas só devem ser retiradas por Pessoal da Assistência devidamente treinado e depois de a energia eléctrica ter sido desligada. Algumas superfícies permanecem quentes até 45 minutos depois. 
9. Sempre que o equipamento ou as tampas contiverem o símbolo, o Manual de Funcionamento deve ser consultado para obtenção das necessárias instruções. 
10. Todos os símbolos gráficos utilizados neste produto baseiam-se em uma ou mais das seguintes normas: EN61010-1, IEC417 e ISO3864.

IMPORTANTE

Instrucciones de seguridad para el montaje y cableado de este aparato.



Las siguientes instrucciones de seguridad , son de aplicacion especifica a todos los miembros de la UE y se adjuntaran para cumplir la normativa europea de baja tension.

1. Se deben preveer conexiones a tierra del equipo, tanto externa como internamente, en aquellos terminales previstos al efecto.
2. Una vez finalizada las operaciones de mantenimiento del equipo, se deben volver a colocar las cubiertas de seguridad aasi como los terminales de tierra. Se debe comprobar la integridad de cada terminal.
3. Los cables de alimentacion electrica cumplan con las normas IEC 227 o IEC 245.
4. Todo el cableado sera adecuado para una temperatura ambiental de 75°C.
5. Todos los prensaestopas seran adecuados para una fijacion adecuada de los cables.
6. Para un manejo seguro del equipo, la alimentacion electrica se realizara a traves de un interruptor magnetotermico (min 10 A), el cual desconectara la alimentacion electrica al equipo en todas sus fases durante un fallo. Los interruptores estaran de acuerdo a la norma IEC 947 u otra de reconocido prestigio.
7. Cuando las tapas o el equipo lleve impreso el simbolo de tension electrica peligrosa, dicho alojamiento solamente se abra una vez que se haya interrumpido la alimentacion electrica al equipo asimismo la intervencion sera llevada a cabo por personal entrenado para estas labores. 
8. Cuando las tapas o el equipo lleve impreso el simbolo, hay superficies con alta temperatura, por tanto se abra una vez que se haya interrumpido la alimentacion electrica al equipo por personal entrenado para estas labores, y al menos se esperara unos 45 minutos para enfriar las superficies calientes. 
9. Cuando el equipo o la tapa lleve impreso el simbolo, se consultara el manual de instrucciones. 
10. Todos los simbolos graficos usados en esta hoja, estan de acuerdo a las siguientes normas EN61010-1, IEC417 & ISO 3864.

VIKTIGT

Säkerhetsföreskrifter för kablage och installation av denna apparat.

Följande säkerhetsföreskrifter är tillämpliga för samtliga EU-medlemsländer. De skall följas i varje avseende för att överensstämma med Lågspännings direktivet. Icke EU medlemsländer skall också följa nedanstående punkter, såvida de inte övergrips av lokala eller nationella föreskrifter.

1. Tillämplig jordkontakt skall utföras till alla jordade punkter, såväl internt som externt där så erfordras.
2. Efter installation eller felsökning skall samtliga säkerhetsköljen och säkerhetsjord återplaceras. Samtliga jordterminaler måste hållas obrutna hela tiden.
3. Matningsspänningens kabel måste överensstämma med föreskrifterna i IEC227 eller IEC245.
4. Allt kablage skall vara lämpligt för användning i en omgivningstemperatur högre än 75°C.
5. Alla kabelförskruvningar som används skall ha inre dimensioner som motsvarar adekvat kabelförankring.
6. För att säkerställa säker drift av denna utrustning skall anslutning till huvudströmmen endast göras genom en säkring (min 10A) som skall frångörpla alla strömförande kretsar när något fel uppstår. Säkringen kan även ha en mekanisk frånskiljare. Om så inte är fallet, måste ett annat förfarande för att frånskilja utrustningen från strömförsörjning tillhandahållas och klart framgå genom markering. Säkring eller omkopplare måste överensstämma med en gällande standard såsom t ex IEC947.
7. Där utrustning eller hölje är markerad med vidstående symbol föreligger risk för livsfarlig spänning i närheten. Dessa höljen får endast avlägsnas när strömmen ej är ansluten till utrustningen - och då endast av utbildad servicepersonal. 
8. När utrustning eller hölje är markerad med vidstående symbol föreligger risk för brännskada vid kontakt med uppvärmd yta. Dessa höljen får endast avlägsnas av utbildad servicepersonal, när strömmen kopplats från utrustningen. Vissa ytor kan vara mycket varma att vidröra även upp till 45 minuter efter avstängning av strömmen. 
9. När utrustning eller hölje markerats med vidstående symbol bör instruktionsmanualen studeras för information. 
10. Samtliga grafiska symboler som förekommer i denna produkt finns angivna i en eller flera av följande föreskrifter:- EN61010-1, IEC417 & ISO3864.

ΠΡΟΣΟΧΗ

Οδηγίες ασφαλείας για την καλωδίωση και εγκατάσταση της συσκευής.

Οι ακόλουθες οδηγίες ασφαλείας εφαρμόζονται ειδικά σε όλες τις χώρες μέλη της Ευρωπαϊκής Κοινότητας. Θα πρέπει να ακολουθούνται αυστηρά ώστε να εξασφαλιστεί η συμβατότητα με τις οδηγίες για τη Χαμηλή Τάση. Χώρες που δεν είναι μέλη της Ευρωπαϊκής Κοινότητας θα πρέπει επίσης να ακολουθούν τις οδηγίες εκτός εάν αντικαθίστανται από τα Τοπικά ή Εθνικά Πρότυπα.



1. Επαρκείς συνδέσεις γείωσης θα πρέπει να γίνονται σε όλα τα σημεία γείωσης, εσωτερικά και εξωτερικά όπου υπάρχουν.
2. Μετά την εγκατάσταση ή την εκσφαλμάτωση όλα τα καλύματα ασφαλείας και οι γειώσεις ασφαλείας πρέπει να επανεγκαθίστανται. Η καλή κατάσταση όλων των ακροδεκτών γείωσης πρέπει να ελέγχεται και να συντηρείται διαρκώς.
3. Τα καλώδια τροφοδοσίας πρέπει να πληρούν τις απαιτήσεις των IEC227 ή IEC245.
4. Όλες οι καλωδιώσεις θα πρέπει είναι κατάλληλες για χρήση σε ατμοσφαιρική θερμοκρασία χώρου υψηλότερη από 75°C.
5. Όλοι οι στυπιοθλίπτες θα πρέπει να είναι τέτοιων εσωτερικών διαστάσεων ώστε να παρέχουν επαρκή στερέωση των καλωδίων.
6. Για τη διασφάλιση ασφαλούς λειτουργίας της σύνδεσης τροφοδοσίας αυτής της συσκευής θα πρέπει να γίνεται μόνο μέσω ασφαλειοδιακόπτη (ελάχιστο 10A) ο οποίος θα αποσυνδέει όλους του ηλεκτροφόρους αγωγούς στη διάρκεια κατάστασης σφάλματος.
Ο ασφαλειοδιακόπτης μπορεί επίσης να περιλαμβάνει μηχανικό διακόπτη απομόνωσης. Εάν δεν περιλαμβάνει, τότε άλλα μέσα αποσύνδεσης της συσκευής από την τροφοδοσία πρέπει να παροχρηθούν και σαφώς να σημειθούν σαν τέτοια. Οι ασφαλειοδιακόπτες ή διακόπτες πρέπει να συμφωνούν με αναγνωρισμένα πρότυπα όπως το IEC947.
7. Όπου συσκευές ή καλύματα είναι σημασμένα με το σύμβολο επικίνδυνες τάσεις ενυπάρχουν κάτω από αυτά.
Αυτά τα καλύματα θα πρέπει να αφαιρούνται μόνο όταν έχει αφαιρεθεί η τροφοδοσία από τη συσκευή και τότε μόνο από ειδικευμένο τεχνικό προσωπικό.
8. Όπου συσκευές ή καλύματα είναι σημασμένα με το σύμβολο υπάρχει κίνδυνος από καυτές επιφάνειες κάτω από αυτά.
Αυτά τα καλύματα θα πρέπει να αφαιρούνται μόνο από ειδικευμένο τεχνικό προσωπικό, όταν η τροφοδοσία έχει αφαιρεθεί από τη συσκευή. Τέτοιες επιφάνειες μπορούν να παραμείνουν ζεστές στην αφή έως και 45 λεπτά αργότερα.
9. Όπου συσκευές ή καλύματα είναι σημασμένα με το σύμβολο αναφερθείται στις οδηγίες χρήσης της συσκευής.
10. Όλα τα γραφικά σύμβολα που χρησιμοποιούνται σε αυτό το προϊόν είναι από ένα ή περισσότερα από τα έξης πρότυπα: EN61010-1, IEC417 και ISO3864.

TABLE OF CONTENTS

Section	Page
Rosemount Warranty	i
I DESCRIPTION	1-1
1-1. Component Checklist of Typical System (Package Contents)	1-1
1-2. Overview.....	1-1
II INSTALLATION	2-1
2-1. Oxygen Analyzer (Probe) Installation.....	2-1
2-2. Heater Power Supply Installation.....	2-7
III SETUP AND TROUBLESHOOTING	3-1
3-1. Overview.....	3-1
3-2. Models 218, 225, and 132 (Analog) Electronics Setup	3-1
3-3. Model 218A Electronics Setup	3-2
3-4. Model TC200 VERITRIM Electronics Setup	3-3
3-5. Model 132 Digital Electronics Setup	3-4
IV TROUBLESHOOTING	4-1
4-1. Overview.....	4-1
4-2. System Troubleshooting.....	4-1
V RETURNING EQUIPMENT TO THE FACTORY	5-1
INDEX	I-1
 APPENDIX A. WORLD CLASS 3000 OXYGEN ANALYZER (PROBE)	
 APPENDIX B. HPS 3000 HEATER POWER SUPPLY FIELD MODULE	

LIST OF ILLUSTRATIONS

Figure	Page
1-1 Typical System Package.....	1-1
1-2 Typical System Installation	1-3
1-3 Typical System Wiring.....	1-4
2-1 Probe Installation.....	2-2
2-2 Orienting the Optional Vee Deflector	2-6
2-3 Outline of Heater Power Supply	2-7
2-4 Electrical Installation of Heater Power Supply	2-8
2-5 Heater Power Supply Wiring Connections	2-9
2-6 Jumper Selection Label	2-10
2-7 Jumpers on HPS Mother Board	2-10
3-1 Temperature Controller Card Calibration Points.....	3-1
3-2 Main PCB (Model 218A) EPROM Replacement.....	3-2
3-3 Main PCB (Model TC200) EPROM Replacement	3-3
3-4 Main PCB (Model 132) EPROM Replacement	3-4

SECTION I. DESCRIPTION

1-1. **COMPONENT CHECKLIST OF TYPICAL SYSTEM (PACKAGE CONTENTS).** A typical Rosemount World Class 3000 Oxygen Analyzer with HPS 3000 Heater Power Supply package should contain the items shown in Figure 1-1. Record the Part Number, Serial Number, and Order Number for each component of your system in the table located on the first page of this manual.

Analyzer (Probe) to be interfaced to a number of different and earlier model electronic packages. These electronic packages are not covered in this manual. For specific information concerning calibration and operation of the system, refer to the Instruction Bulletin applicable to your electronics package.

1-2. **OVERVIEW.**

a. **Scope.** This Instruction Bulletin has been designed to supply details needed to install, start up, and troubleshoot the Rosemount World Class 3000 Oxygen Analyzer with HPS 3000 Heater Power Supply Field Module. The Heater Power Supply allows the World Class 3000 Oxygen

b. **System Description.** The Rosemount Oxygen Analyzer (Probe) is designed to measure the net concentration of oxygen in an industrial process; i.e., the oxygen remaining after all fuels have been oxidized. The probe is permanently positioned within an exhaust duct or stack and performs its task without the use of a sampling system.

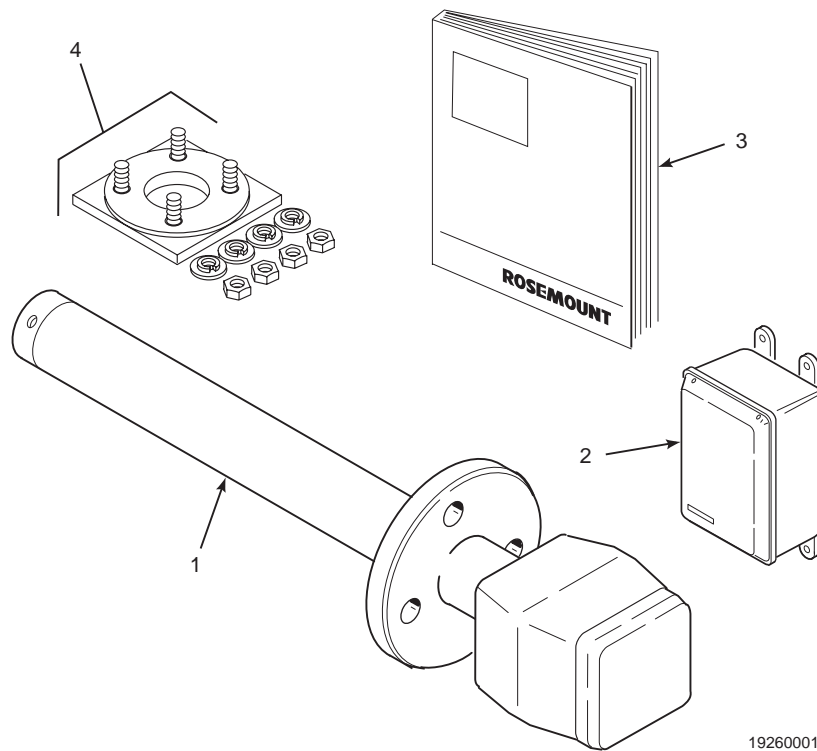

19260001

1. Oxygen Analyzer (Probe)
2. Heater Power Supply
3. Instruction Bulletin
4. Mounting Adaptor Plate with Mounting Hardware and Gasket

Figure 1-1. Typical System Package

The equipment measures oxygen percentage by reading the voltage developed across a heated electrochemical cell, which consists of a small yttria-stabilized, zirconia disc. Both sides of the disc are coated with porous metal electrodes. When operated at the proper temperature, the millivolt output voltage of the cell is given by the following Nernst equation:

$$EMF = KT \log_{10}(P_1/P_2) + C$$

Where:

1. P2 is the partial pressure of the oxygen in the measured gas on one side of the cell,
2. P1 is the partial pressure of the oxygen in the reference gas on the other side,
3. T is the absolute temperature,
4. C is the cell constant,
5. K is an arithmetic constant.

NOTE

For best results, use clean, dry, instrument air (20.95% oxygen) as a reference gas.

When the cell is at operating temperature and there are unequal oxygen concentrations across the cell, oxygen ions will travel from the high partial pressure of oxygen side to the low partial pressure side of the cell. The resulting logarithmic output voltage is approximately 50 mV per decade. Because the magnitude of the output is proportional to the logarithm of the inverse of the sample of the oxygen partial pressure, the output signal increases as the oxygen concentration of the sample gas decreases. This characteristic enables the oxygen analyzer to provide exceptional sensitivity at low oxygen concentrations.

Oxygen analyzer equipment measures net oxygen concentration in the presence of all the products of combustion, including water vapor. Therefore, it may be considered an analysis on a "wet" basis. In comparison with older methods, such as the Orsat apparatus, which provides an analysis on a "dry" gas basis, the "wet" analysis will, in general, indicate a lower percentage of oxygen. The difference will be proportional to the water content of the sampled gas stream.

- c. **System Configuration.** The equipment discussed in this manual consists of two major components; the oxygen analyzer (probe), and the heater power supply.

Probes are available in five length options, giving the user the flexibility to use an in situ penetration appropriate to the size of the stack or duct. The options on length are 18 inches (457 mm), 3 feet (0.91 m), 6 feet (1.83 m), 9 feet (2.74 m), or 12 feet (3.66 m).

The heater power supply (HPS) provides an interface to the electronics package and contains a transformer for supplying proper voltage to the 44 Vac and 115 Vac probe heaters. The enclosure has been designed to meet NEMA 4X (IP56) specifications for water tightness; an optional enclosure to meet Class 1, Division 1, Group B (IP56) explosion-proof is also available.

The oxygen analyzer is connected to the HPS and electronics package using seven wires housed within the connecting system cable.

- d. **Features.**

1. Unique and patented cell protection action that automatically protects sensor cell when analyzer detects reducing atmospheres.
2. Output voltage and sensitivity increase as the oxygen concentration decreases.
3. In situ, non sampling analyzer.
4. Field replaceable cell.
5. Analyzer constructed of rugged 316 LSS for all wetted parts.
6. Suitable for use in temperatures up to 1300°F (700°C).
7. Heater power supply allows World Class 3000 probe to be interfaced with existing analog and 218A digital electronic packages.
8. Optional explosion-proof HPS enclosure allows use in hazardous gas areas.

e. Handling the Oxygen Analyzer.

CAUTION

It is important that printed circuit boards and integrated circuits are handled only when adequate antistatic precautions have been taken to prevent possible equipment damage.

The oxygen analyzer is designed for industrial application. Treat each component of the system with care to avoid physical damage. The probe contains components made from ceramics, which are susceptible to shock when mishandled.

NOTE

Retain packaging in which the oxygen analyzer arrived from the factory in case any components are to be shipped to another site. This packaging has been designed to protect the product.

f. System Considerations. Prior to installation of your Rosemount World Class 3000 Oxygen Analyzer with Heater Power Supply Field Module, make sure you have all of the components necessary to make the system installation. Ensure all components are properly integrated to make the system functional.

Once you have verified you have all the components, select mounting locations and determine how each component will be placed in terms of available power supply, ambient temperatures, environmental considerations, convenience, and serviceability. A typical installation is illustrated in Figures 1-2 and 1-3.

After selecting the probe mounting location, provision should be made for a platform where the probe can be easily serviced. The heater power supply can be located up to 150 feet (45 m) cable distance from the probe.

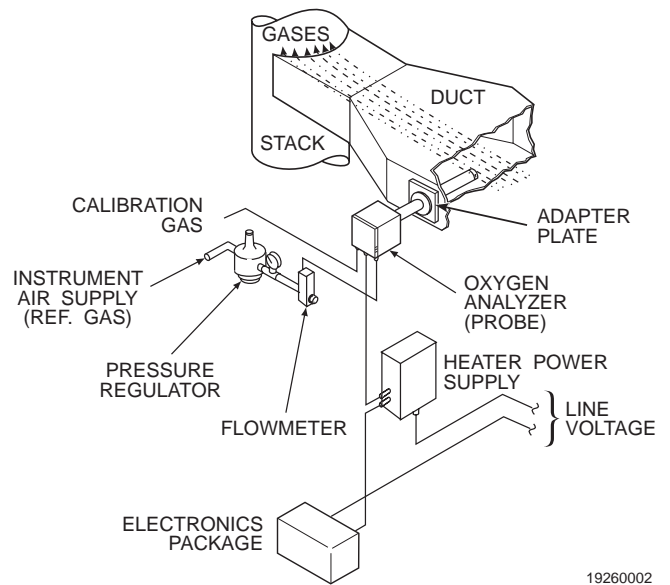

1926002

Figure 1-2. Typical System Installation

A source of instrument air is required at the probe for reference gas use. Since the probe is equipped with an in place calibration feature, provision should be made for connecting test gas tanks to the oxygen analyzer when the probe is to be calibrated.

NOTE

Ambient air is not recommended for use as high test gas. An 8% O₂ balance in nitrogen is recommended for high test gas.

If test gas bottles will be hooked up permanently, a check valve is required next to the calibration fittings on the probe junction box. This is to prevent breathing of calibration gas line and subsequent flue gas condensation and corrosion. The check valve is in addition to the stop valve in the test gas kit or the solenoid valve in the multiprobe test gas sequencer units.

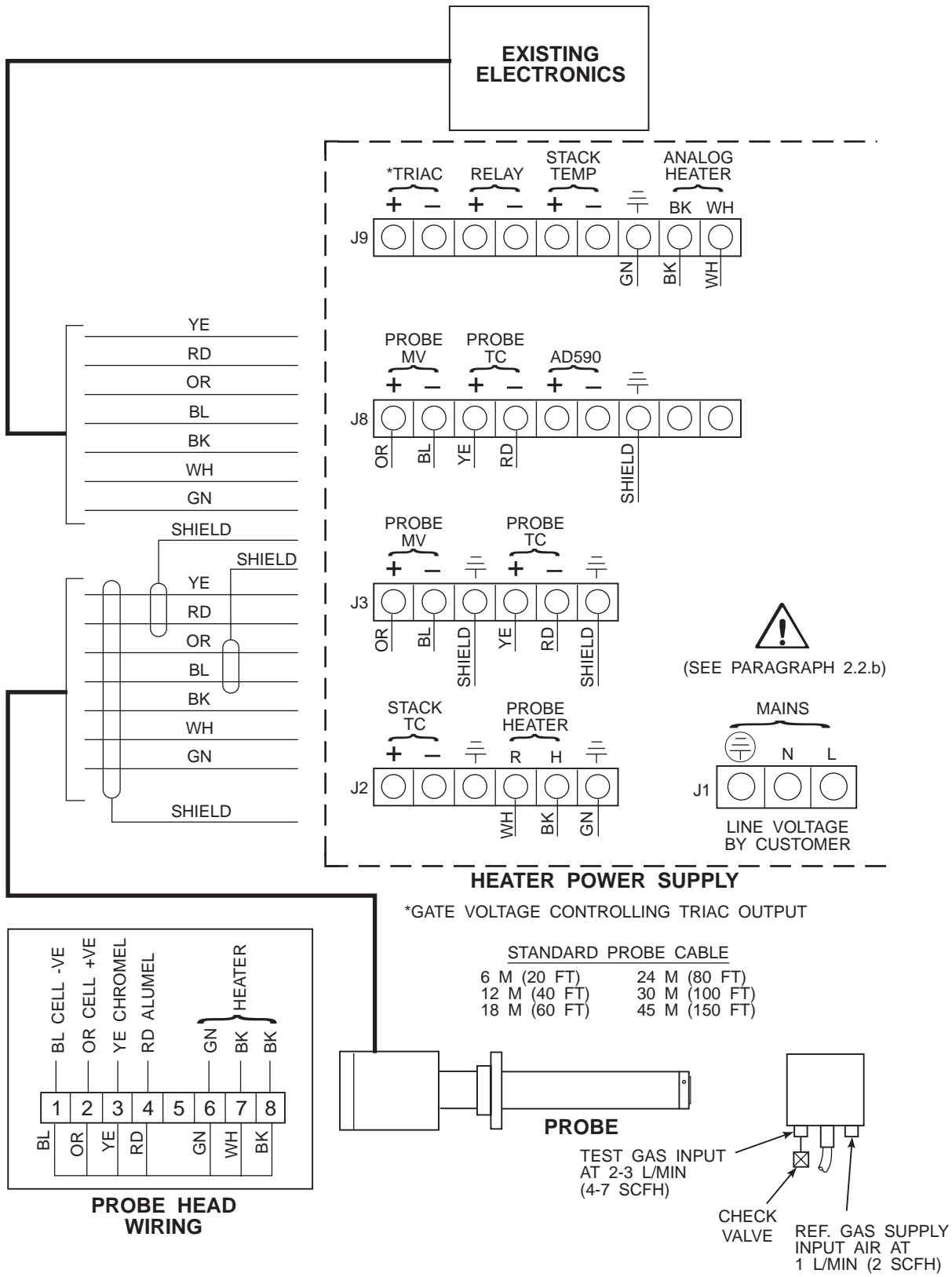

Figure 1-3. Typical System Wiring

SECTION II. INSTALLATION

2-1. OXYGEN ANALYZER (PROBE) INSTALLATION.

WARNING

Before starting to install this equipment, read the "Safety instructions for the wiring and installation of this apparatus" at the front of this Instruction Bulletin. Failure to follow the safety instructions could result in serious injury or death.

WARNING

Install all protective equipment covers and safety ground leads after installation. Failure to install covers and ground leads could result in serious injury or death.

a. Selecting Location.

1. The location of the probe in the stack or flue is most important for maximum accuracy in the oxygen analyzing process. The probe must be positioned so that the gas it measures is representative of the process. Best results are normally obtained if the probe is positioned near the center of the duct (40 to 60% insertion). A point too near the edge or wall of the duct may not provide a representative sample because of the possibility of gas stratification. In addition, the sensing point should be selected so that the process gas temperature falls within a range of 50° to 1300°F (10° to 704°C). Figure 2-1 provides mechanical installation references.
2. Check the flue or stack for holes and air leakage. The presence of this condition will substantially affect the accuracy of the oxygen reading. Therefore, either make necessary repairs or install the probe upstream of any leakage.
3. Ensure that the area is clear of obstructions internal and external that will interfere with installation. Allow adequate clearance for removal of probe (Figure 2-1).

CAUTION

Do not allow the temperature of the probe junction box to exceed 300°F (149°C) or damage to the unit may result. If the probe junction box temperature exceeds 300°F (149°C), the user must fabricate a heat shield or provide adequate cooling air to the probe junction box.

b. Mechanical Installation.

1. Ensure that all components are available for installation of the probe. Ensure that the system cable is the required length. If applicable, check the ceramic filter to ensure that it is not damaged.
2. The probe may be installed intact as it is received. It is recommended that you disassemble the adapter plate for each installation.

NOTE

An abrasive shield is recommended for high velocity particulate in the flue stream (such as those in pulverized coal kilns and recovery boilers). Vertical and horizontal brace clamps are provided for 9 ft and 12 ft (2.75 m and 3.66 m) probes to provide mechanical support of the probe. Refer to Figure 2-1, Sheet 5.

3. Weld or bolt adapter plate (Figure 2-1) onto the duct.
4. If using the optional ceramic diffusor element, the vee deflector must be correctly oriented. Before inserting the probe, check the direction of gas flow in the duct. Orient the vee deflector on the probe so that the apex points upstream toward the flow (Figure 2-2). This may be done by loosening the setscrews, and rotating the vee deflector to the desired position. Retighten the setscrews.
5. In horizontal installations, the probe junction box should be oriented so the system cable drops vertically from the probe junction box. In a vertical installation, the system cable can be oriented in any direction.

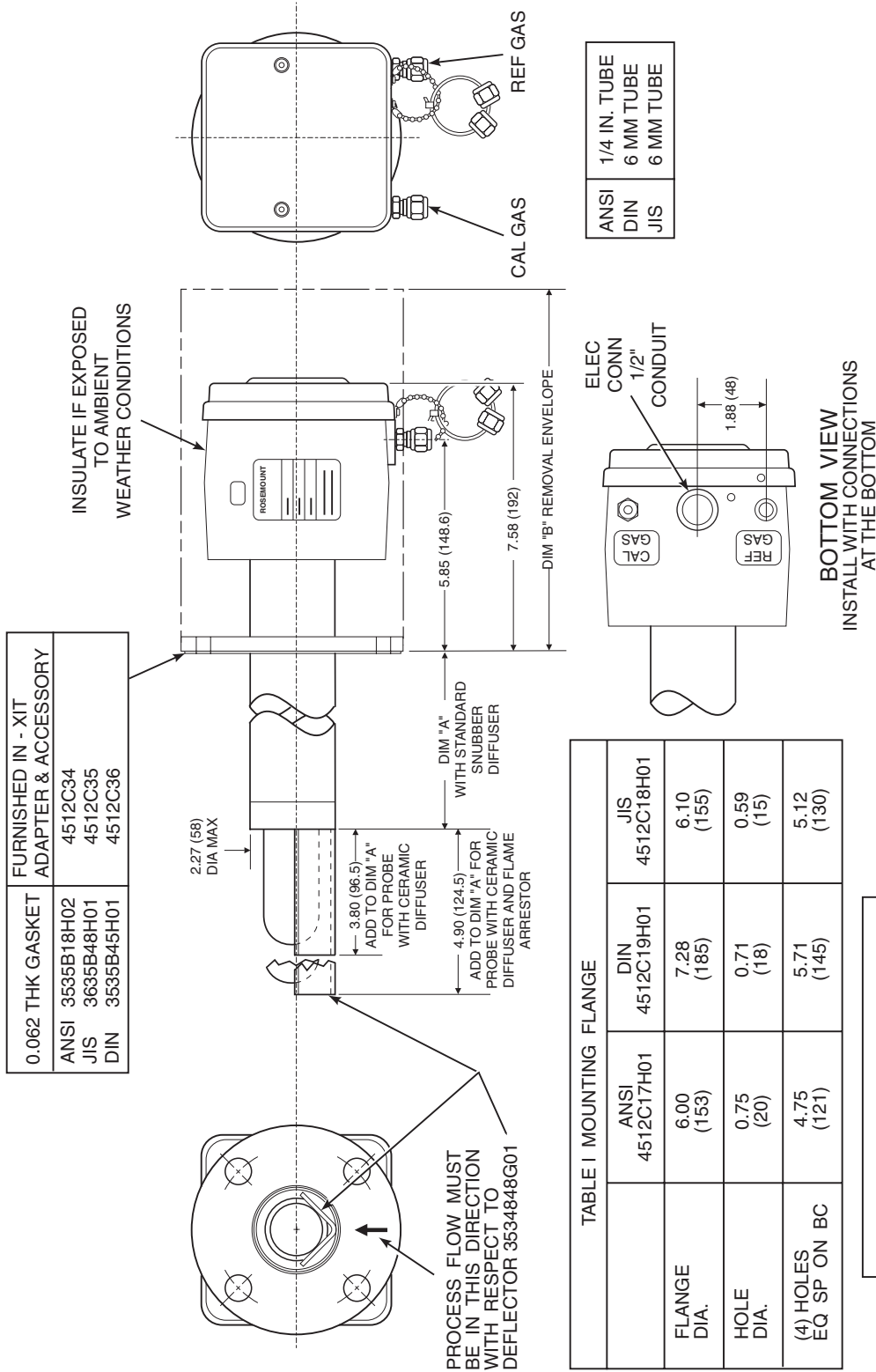

NOTES: 1. DIMENSIONS ARE IN INCHES WITH MILLIMETERS IN PARENTHESES.

2. THESE FLAT FACED FLANGES ARE MANUFACTURED TO ANSI, DIN, AND JIS BOLT PATTERNS AND ARE NOT PRESSURE RATED.

24610001

Figure 2-1. Probe Installation (Sheet 1 of 5)

6. If the system has an abrasive shield, check the diffusion element dust seal packings. The joints in the two packings must be staggered 180°. Also, make sure that the packings are

the hub grooves as the probe slides into the 15° forcing cone in the abrasive shield.

7. Insert the probe through the opening in the mounting flange and bolt the unit to the flange. When probe lengths selected are 9 or 12 feet (2.74 or 3.66 m), special brackets are supplied to provide additional support for the probe inside the flue or stack. See Figure 2-1, sheet 5.

TABLE III. REMOVAL / INSTALLATION NOMINAL MEASUREMENTS			
	DIM "C"	DIM "D"	DIM "E"
3 FT	27 (686)	45.3 (1151)	31.1 (790)
6 FT	63 (1600)	81.3 (2065)	67.1 (1704)
9 FT	99 (2515)	117.3 (2980)	103.1 (2619)
12 FT	135 (3429)	153.3 (3894)	139.1 (3533)

TABLE IV. FLANGE SIZE			
	FLANGE DIAMETER	(8) HOLES DIAMETER	BOLT CIRCLE
ANSI*	9.00 (153)	0.75	7.50
JIS*	9.25 (235)	0.75	7.48
DIN*	9.25 (235)	0.945	7.48

* FLANGES ARE MANUFACTURED TO ANSI, DIN, AND JIS BOLT PATTERNS AND ARE FLAT FACED. THESE FLANGES ARE NOT PRESSURE RATED.

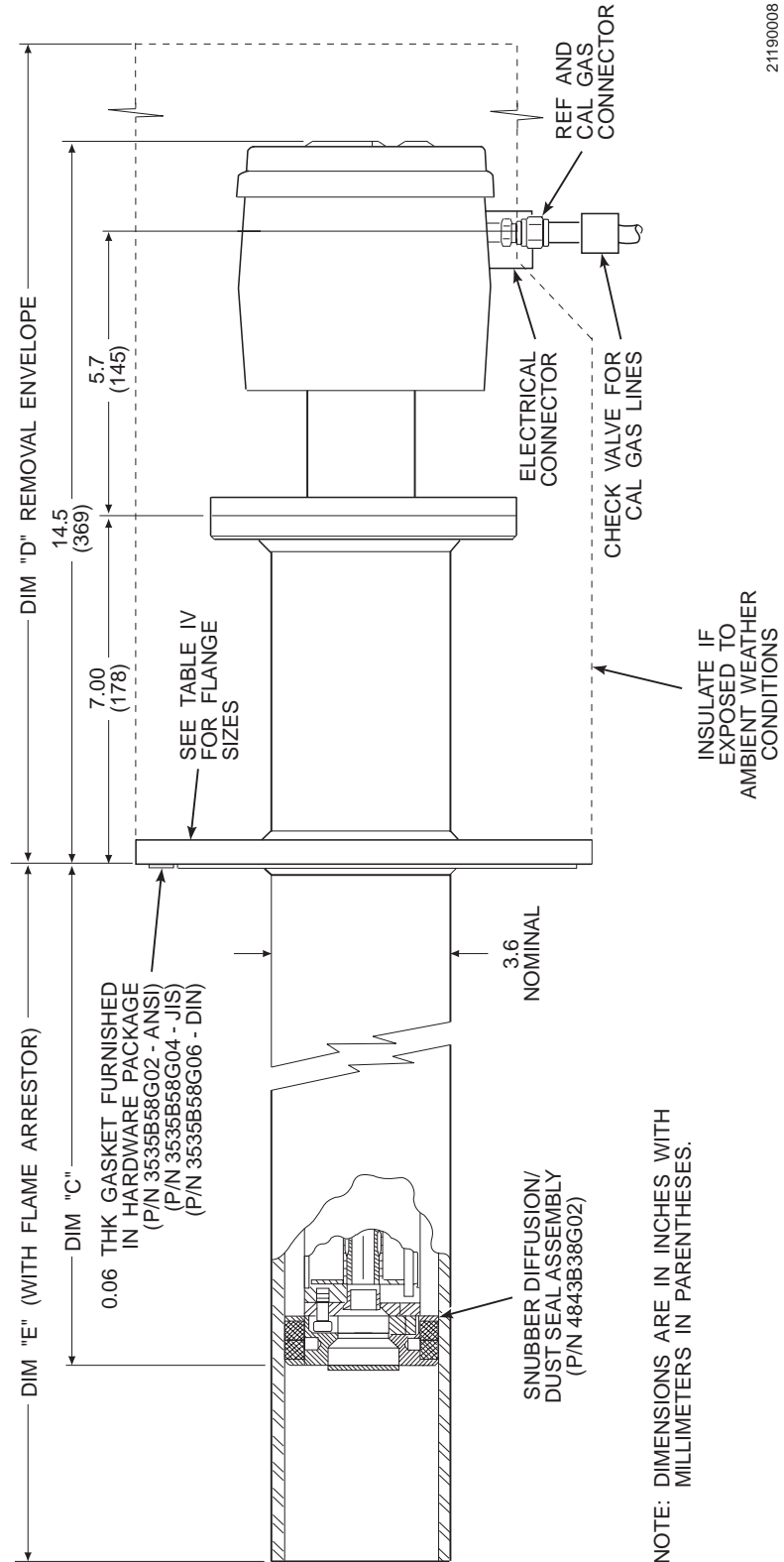

Figure 2-1. Probe Installation (Sheet 2 of 5)

ADAPTOR PLATE OUTLINE

TABLE V. ADAPTOR PLATE DIMENSIONS FOR PROBE			
DIMENSIONS IN. (mm)	ANSI (P/N 4512C34G01)	DIN (P/N 4512C36G01)	JIS (P/N 4512C35G01)
"A"	6.00 (153)	7.5 (191)	6.50 (165)
"B" THREAD	0.625-11	(M-16 x 2)	(M-12 x 1.75)
"C" DIA	4.75 (121)	5.708 (145)	5.118 (130)

NOTE: PART NUMBERS FOR ADAPTOR PLATES INCLUDE ATTACHING HARDWARE.

TABLE VI. ADAPTOR PLATE DIMENSIONS FOR ABRASIVE SHIELD			
DIMENSIONS IN. (mm)	ANSI (P/N 3535B58G02)	DIN (P/N 3535B58G06)	JIS (P/N 3535B58G04)
"A"	9.00 (229)	9.25 (235)	9.25 (235)
"B" DIA	4.75 (121)	3.94 (100)	4.92 (125)
"C" THREAD	0.625-11	(M-16 x 2)	(M-20 x 2.5)
"D" DIA	7.50 (191)	7.48 (190)	7.894 (200)

NOTE: PART NUMBERS FOR ADAPTOR PLATES INCLUDE ATTACHING HARDWARE.

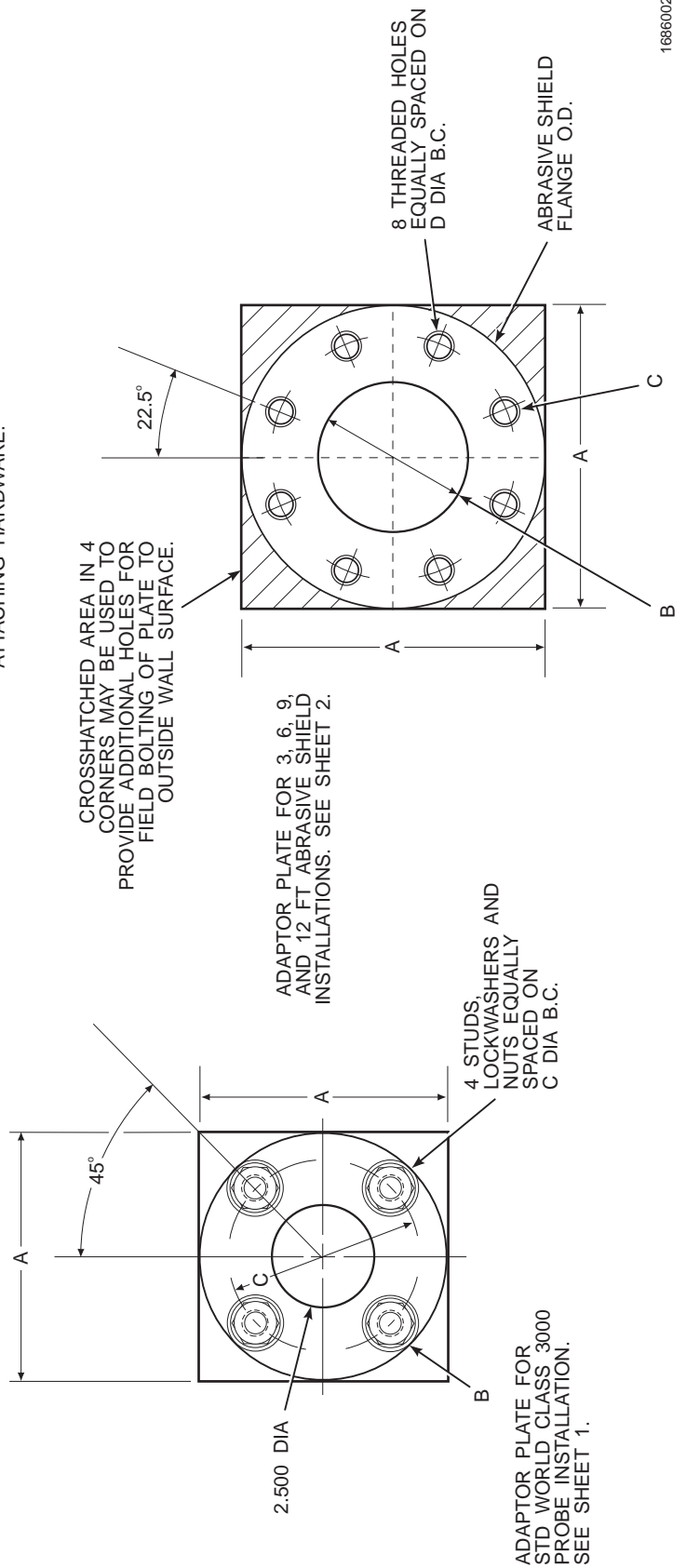
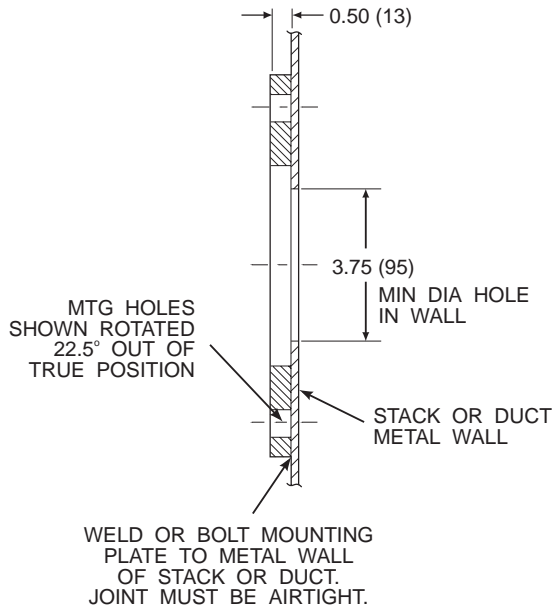
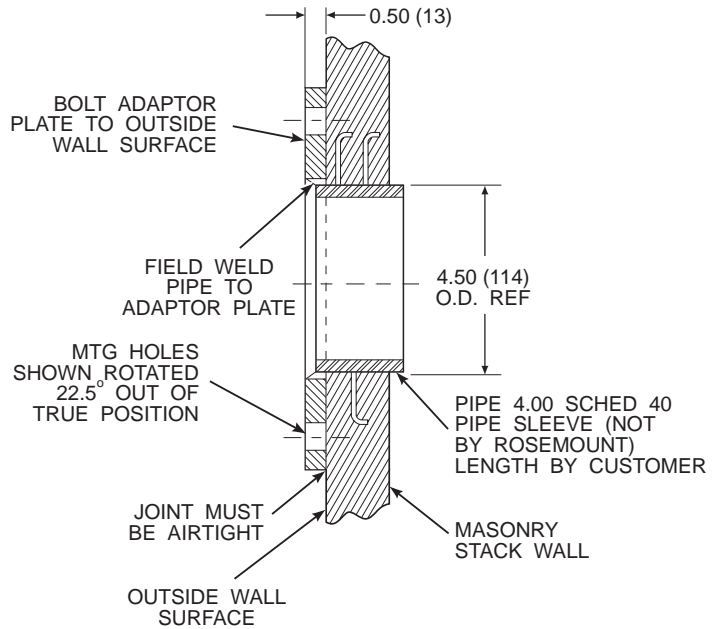

Figure 2-1. Probe Installation (Sheet 3 of 5)

INSTALLATION FOR METAL WALL STACK OR DUCT CONSTRUCTION



INSTALLATION FOR MASONRY WALL STACK CONSTRUCTION



NOTE: ALL MASONRY STACK WORK AND JOINTS EXCEPT ADAPTOR PLATE NOT FURNISHED BY ROSEMOUNT.

ABRASIVE SHIELD MOUNTING

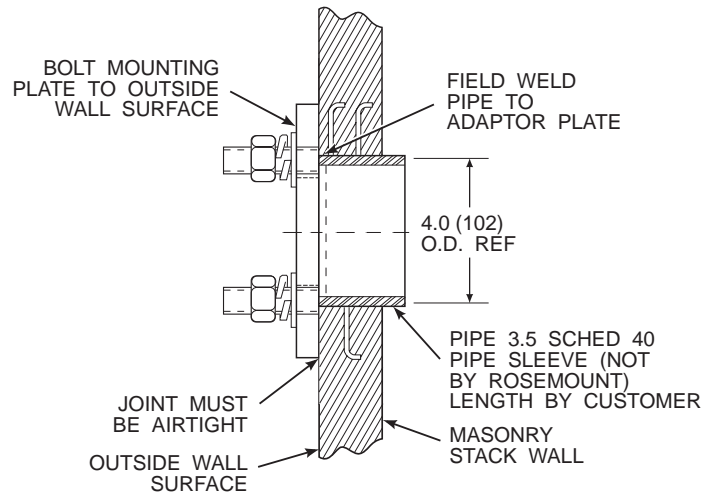
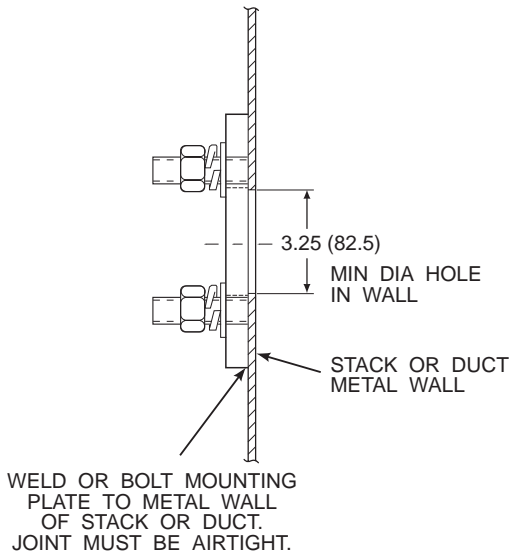

NOTE: DIMENSIONS IN INCHES WITH MILLIMETERS IN PARENTHESES.

PROBE MOUNTING

P0038

Figure 2-1. Probe Installation (Sheet 4 of 5)

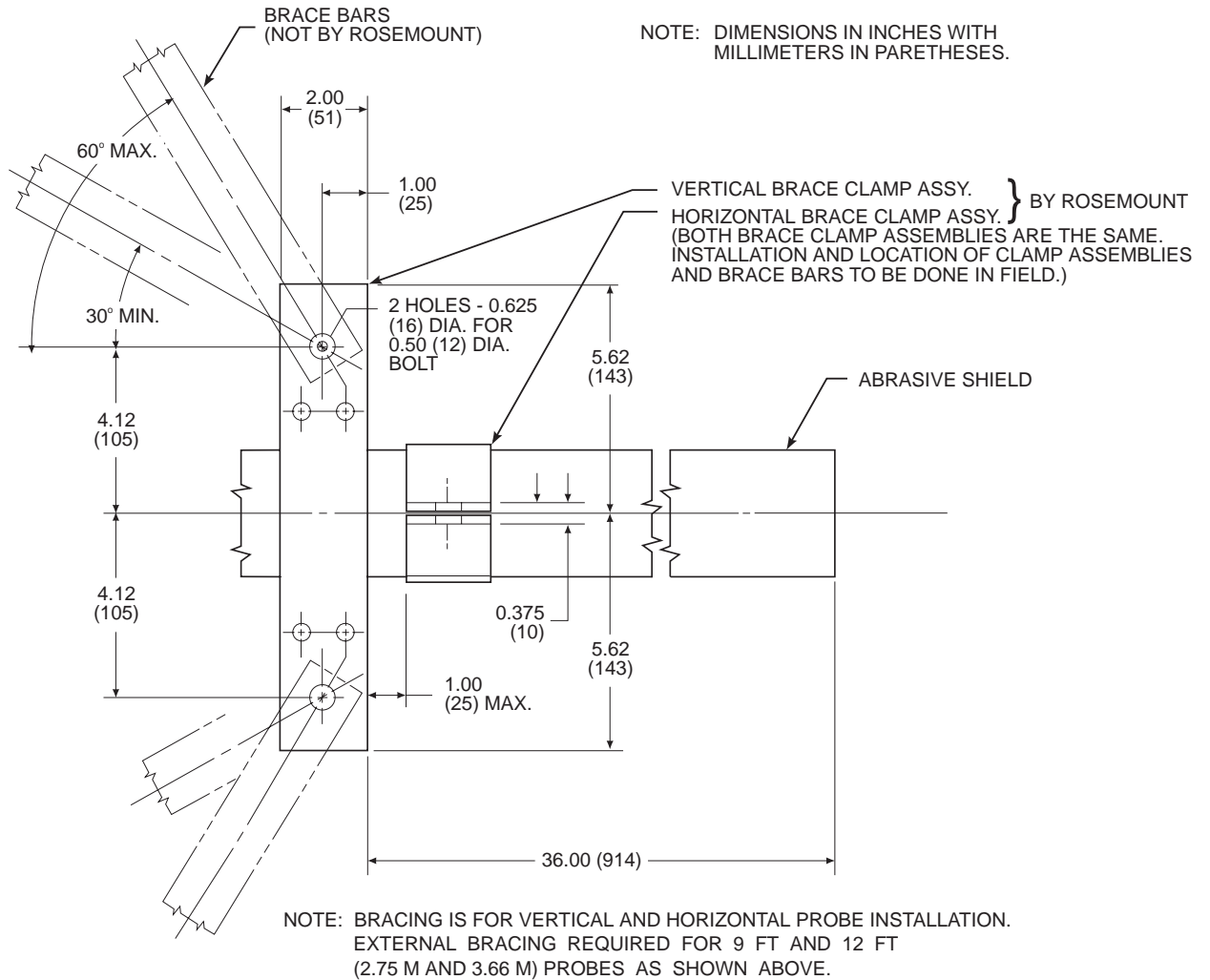

Figure 2-1. Probe Installation (Sheet 5 of 5)

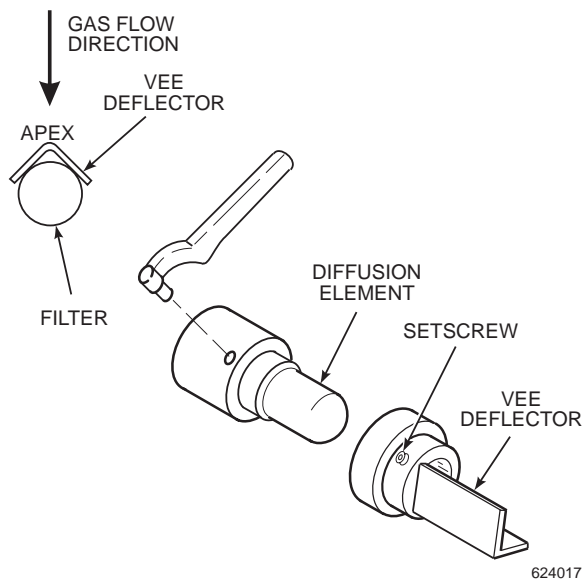

Figure 2-2. Orienting the Optional Vee Deflector

c. Service Required.

1. Power input: 100, 115 or 220 Vac single phase, 50 to 60 Hz, 3 amp minimum. (See label.)
2. Compressed air: 10 psig (68.95 kPag) minimum, 225 psig (1551.38 kPag) maximum at 2 scfh (56.6 L/hr) maximum; supplied by one of the following (less than 40 parts-per-million total hydrocarbons). Regulator outlet pressure should be set at 5 psi (35 kPa).
 - (a) Instrument air - clean, dry.
 - (b) Bottled standard air with step-down regulator.

- (c) Bottled compressed gas mixture (20.95% oxygen in nitrogen).
- (d) Other equivalent clean, dry, oil-free air supply.

2-2. HEATER POWER SUPPLY INSTALLATION.

WARNING

Install all protective equipment covers and safety ground leads after installation. Failure to install covers and ground leads could result in serious injury or death.

a. Mechanical Installation. The outline drawing of the heater power supply enclosure, Figure 2-3, shows mounting centers and clearances. The NEMA 4X enclosure is designed to be mounted on a wall or bulkhead. The heater power supply should be installed no further than 150 feet (45 m) from the probe. The heater power supply must be located in a location free from significant ambient temperature changes and electrical noise. Ambient temperature must be between -20° to 140°F (-30° to 60°C).

b. Electrical Connections.

1. Electrical connections should be made as described in the electrical installation diagram, Figure 2-4. The wiring terminals are divided into two layers; the bottom (FROM PROBE) terminals should be connected first, the top (FROM ELECTRONICS) terminals should be connected last (Figure 2-5). Each terminal strip has a protective cover which must be removed when making connections. To remove the terminal covers, remove two slotted screws holding the cover in place. Always reinstall terminal covers after making connections.

NOTE

Refer to Figure 2-7 for HPS unit fuse locations and specifications.

NOTE

Before supplying power to the heater power supply, verify that jumpers JM2, JM3, JM6, and JM7 are installed.

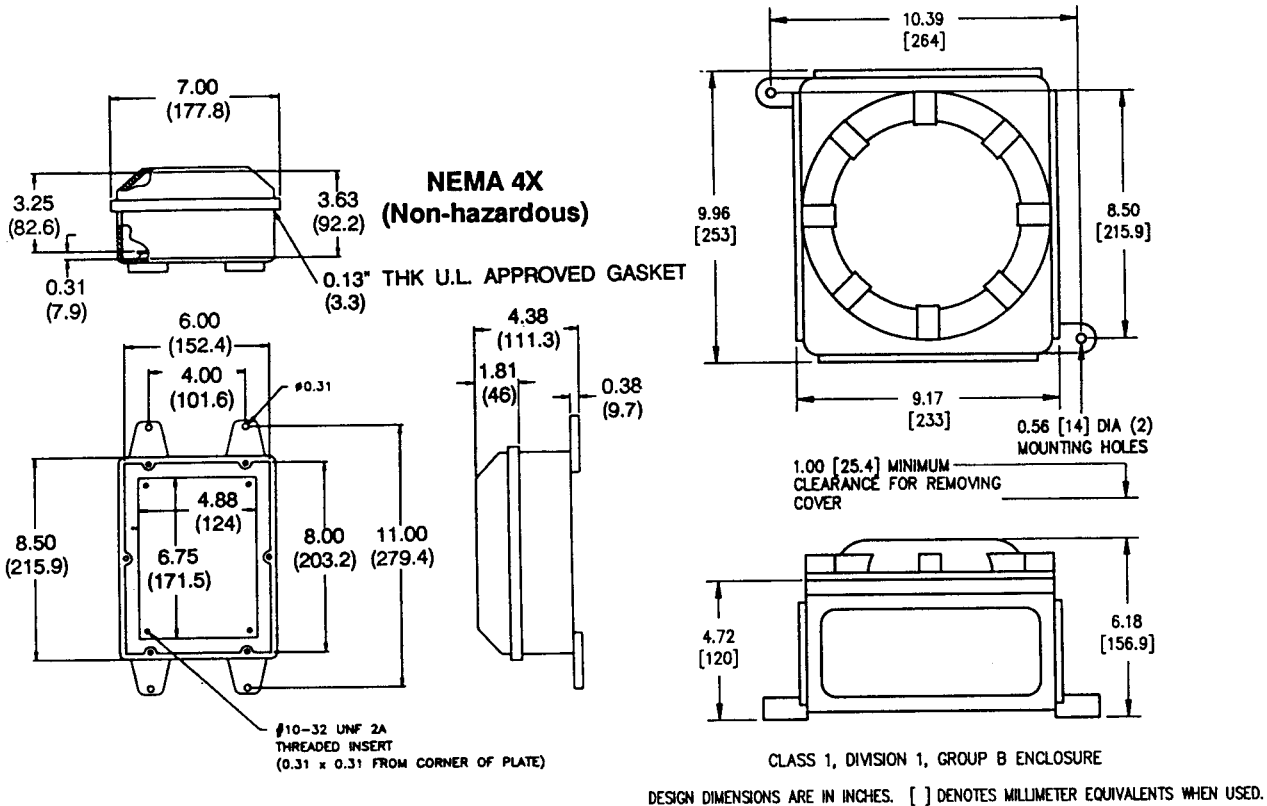

Figure 2-3. Outline of Heater Power Supply

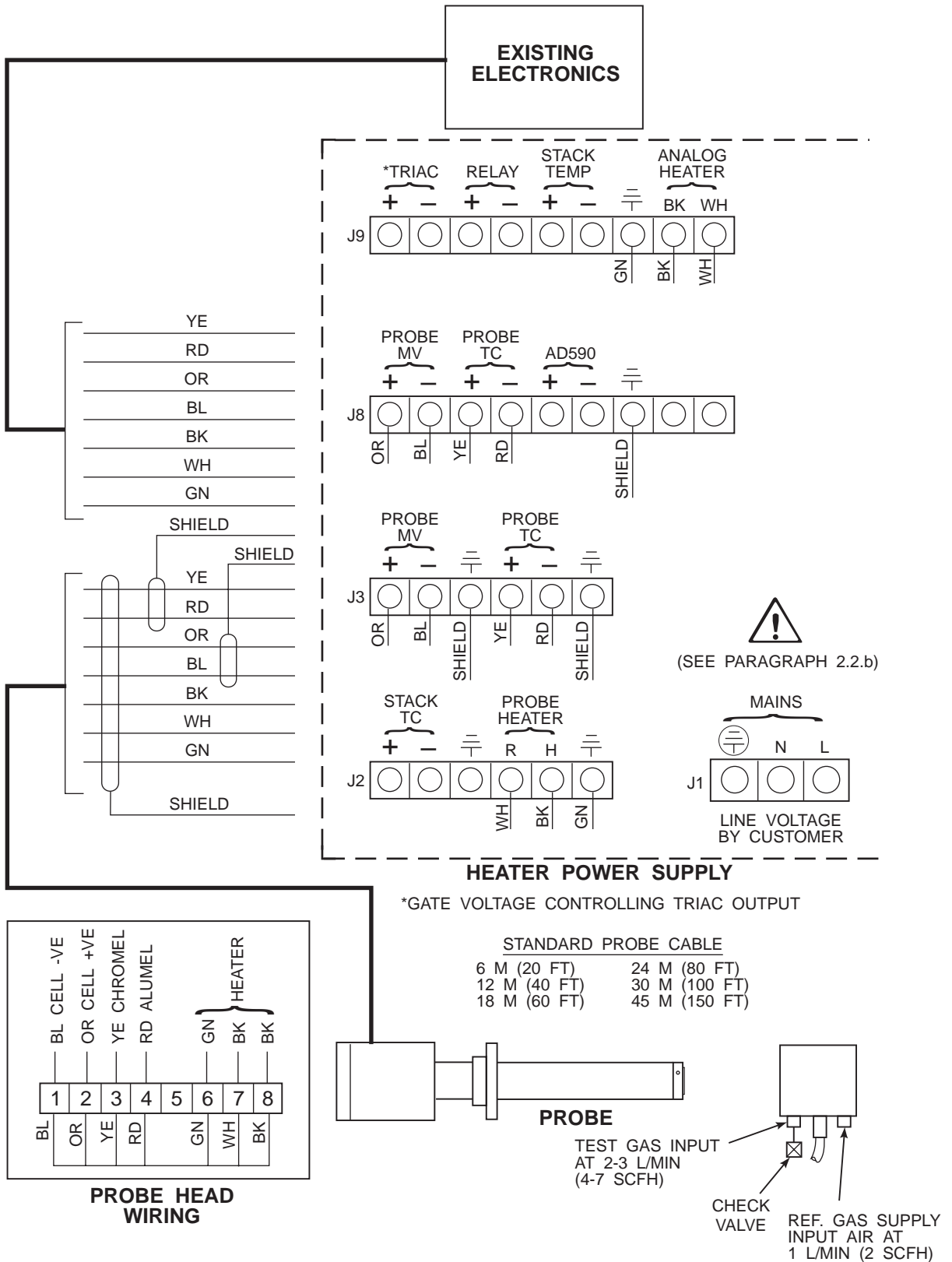

Figure 2-4. Electrical Installation of Heater Power Supply

19260003

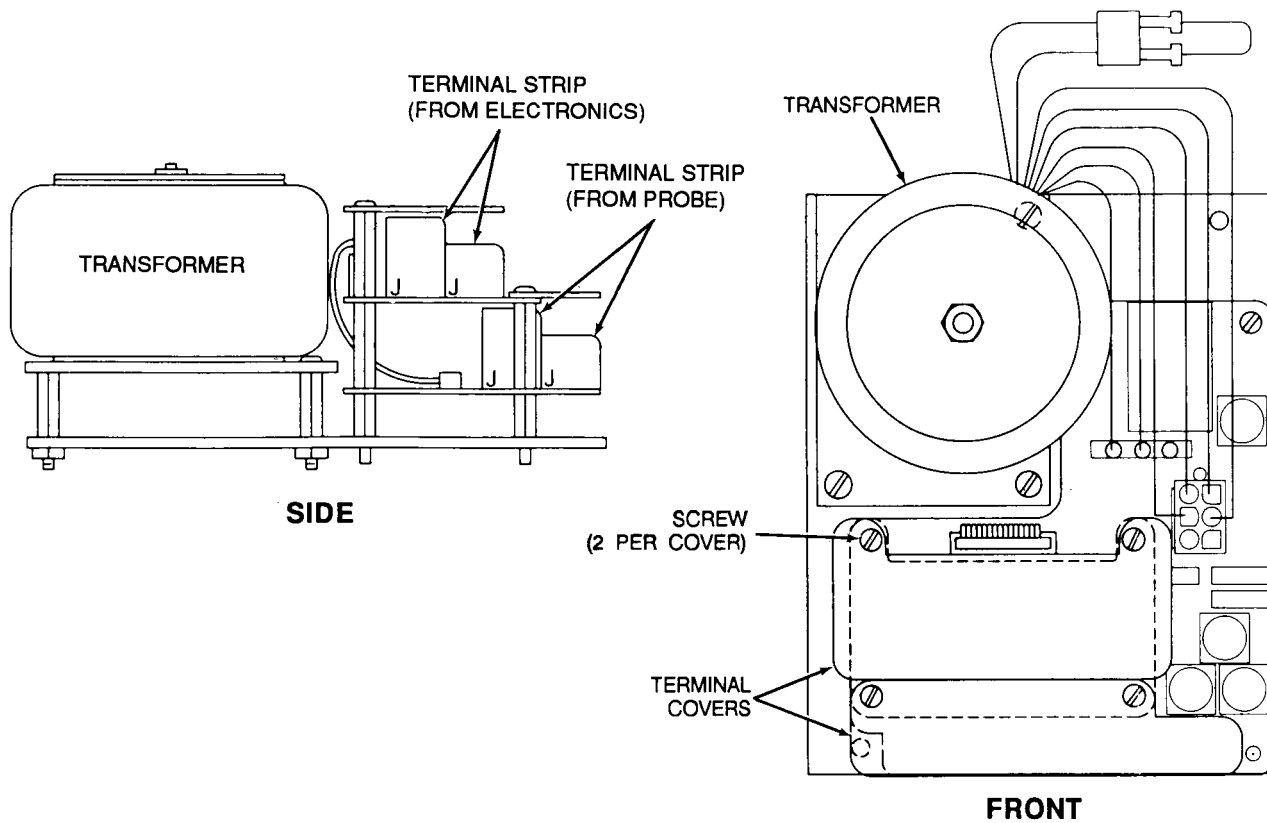

Figure 2-5. Heater Power Supply Wiring Connections

2. Power Input: 120, 220 or 240 Vac. For 120 Vac usage, install jumpers JM4 and JM1. For 220 or 240 Vac usage, install jumper JM5 (See label, Figure 2-6).

For 100 Vac usage, the heater power supply is factory-supplied with a different transformer. When using the HPS with 100 Vac transformer, install jumpers JM1 and JM4.

3. The power cable should comply with all applicable codes and safety regulations in the user's country and should not be smaller than 16 gauge, 3 amp.

NOTE

"ANALOG" under ELECTRONICS SELECTION on the label refers to Models 218, 225, TC200, and Model 218A electronics.

4. Before supplying power to the heater power supply, verify that the jumpers on the mother board, Figure 2-7, are properly configured. Jumpers JM2, JM3, JM6, and JM7 should be installed. Additionally, make sure that the proper jumper for your line voltage is installed, Figure 2-6.

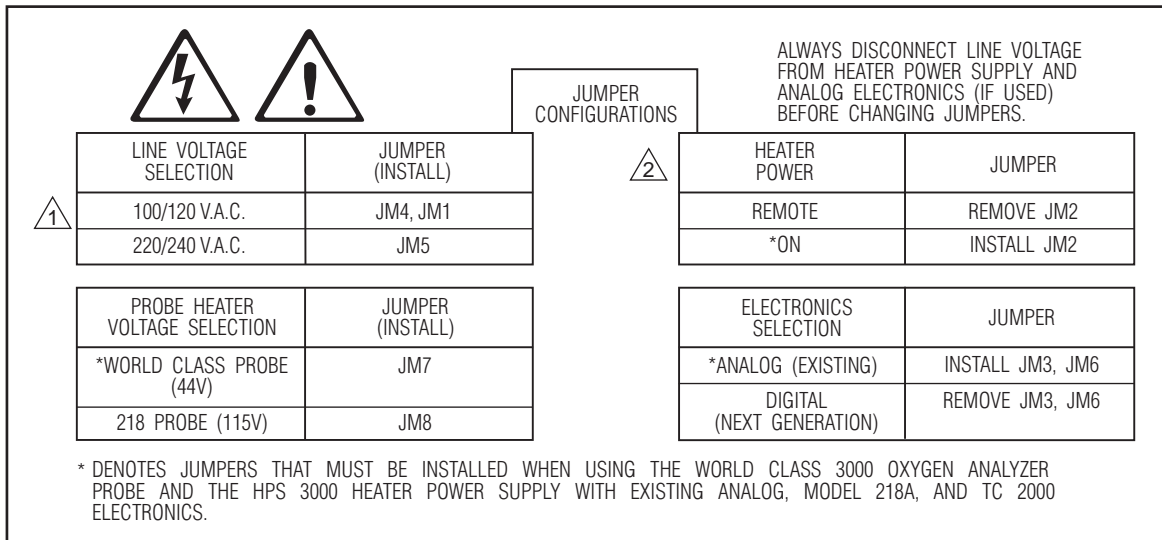

NOTES:

⚠ 100 V.A.C. OPERATION REQUIRES TRANSFORMER PART NUMBER 1M02961G02.

⚠ HEATER POWER IS ALSO REFERRED TO AS LINE VOLTAGE RELAY.

Figure 2-6. Jumper Selection Label

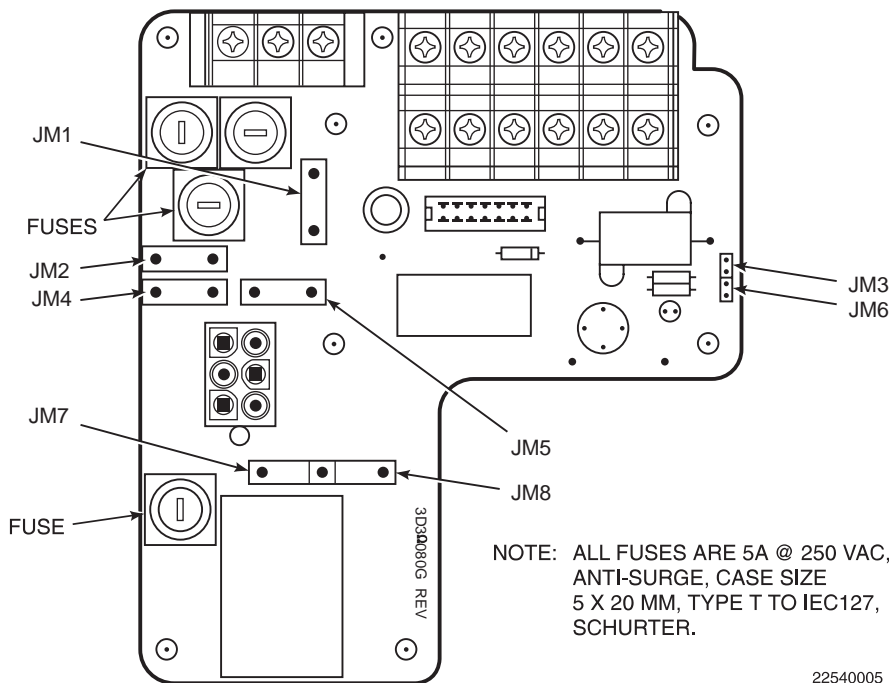

22540005

Figure 2-7. Jumpers on HPS Mother Board



NOTE

Upon completing installation, make sure that the probe is turned on and operating prior to firing up the combustion process. Damage can result from having a cold probe exposed to the process gases.

During outages, and if possible, leave all probes running to prevent condensation and premature aging from thermal cycling.

CAUTION

If the ducts will be washed down during outage, **MAKE SURE** to power down the probes and remove them from the wash area.

SECTION III. SETUP AND TROUBLESHOOTING

3-1. OVERVIEW. This section covers the setup procedures for the World Class 3000 Oxygen Analyzer with HPS 3000 Heater Power Supply Field Module. Since this equipment may be used with a number of different electronics packages, this section has been divided into three parts: Models 218, 225, and 132 (Analog) Electronics, Model 218A, Electronics, and Model TC200 Electronics. Each of the three parts contain setup information applicable to that electronics package.

WARNING

Install all protective equipment covers and safety ground leads after setup. Failure to replace covers and ground leads could result in serious injury or death.

Models 218, 225, and 132 (Analog) Electronics refer to paragraph 3-2.

Models 218A Electronics refer to paragraph 3-3.

Models TC200 Electronics refer to paragraph 3-4.

Model 132 Digital Electronics refer to paragraph 3-5.

3-2. MODELS 218, 225, AND 132 (ANALOG) ELECTRONICS SETUP. Before beginning operation, it is important that the probe heater set point of the existing electronics be changed to support the World Class 3000 probe. The set point adjustment procedure required for Models 218, 225, and 132 analog electronics is as follows:

- Open electronics enclosure.
- On temperature controller card, Figure 3-1, connect jumper wire from TP3 to either Pin 2 or Pin 7.
- Set voltmeter to read DC millivolts (MV).

- Attach voltmeter with positive (+) lead on TP1 and negative (-) on either Pin 2 or 7.
- Adjust potentiometer M110-1 to read -322.3 millivolts nominal.

NOTE

The voltage given above is for an ambient (machinery space) temperature of 77°F (25°C). For each degree of ambient temperature above or below 77°F (25°C), add or subtract 0.242 mV from the nominal. Example; at 87°F (31°C), the nominal voltage of -322.3 should be increased (made less negative) by 10×0.242 or 2.42 mV, making the adjusted nominal -319.9.

- Remove voltmeter leads.
- Remove jumper wire.

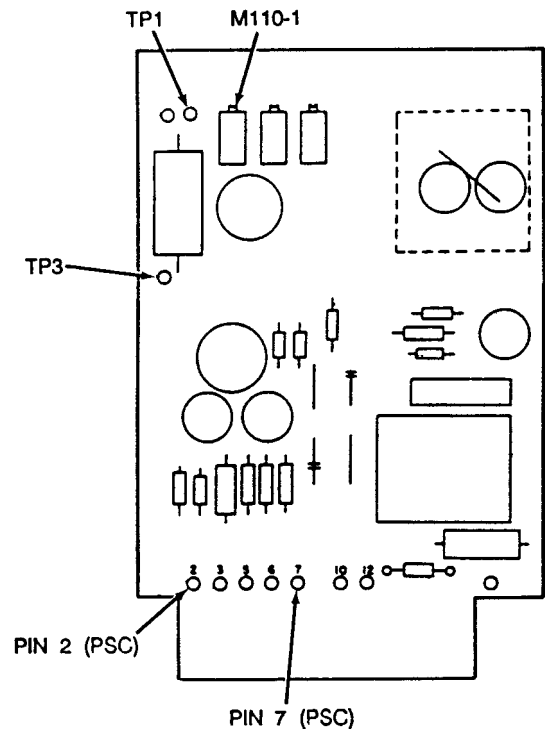

Figure 3-1. Temperature Controller Card Calibration Points

3-3. MODEL 218A ELECTRONICS SETUP. Before beginning operation, it is important that the probe heater set point of the existing electronics be changed to support the World Class 3000 probe. To convert the Model 218A Digital Electronics Package for use with the World Class 3000 Probe and Heater Power Supply, an EPROM change is necessary. Remove Main PCB and check back of board to identify unit as G02 or G04. The replacement EPROM needed is as identified below:

	G02	G04
United States	1M03192G01	1M02982G01
United Kingdom	1M03192G02	1M02982G02
Germany	1M03192G03	1M02982G03
France	1M03192G04	1M02982G04
Italy	1M03192G05	1M02982G05

NOTE

The replacement EPROM when using a multiprobe averager unit is 1M02982G10.

To replace the EPROM, proceed as follows:

- a. Shut off and lock out power to the electronics package.
- b. Open electronics enclosure.
- c. On the Main PCB, Figure 3-2, locate and remove old EPROM.
- d. Replace with new EPROM.
- e. Close electronics enclosure and power up system.

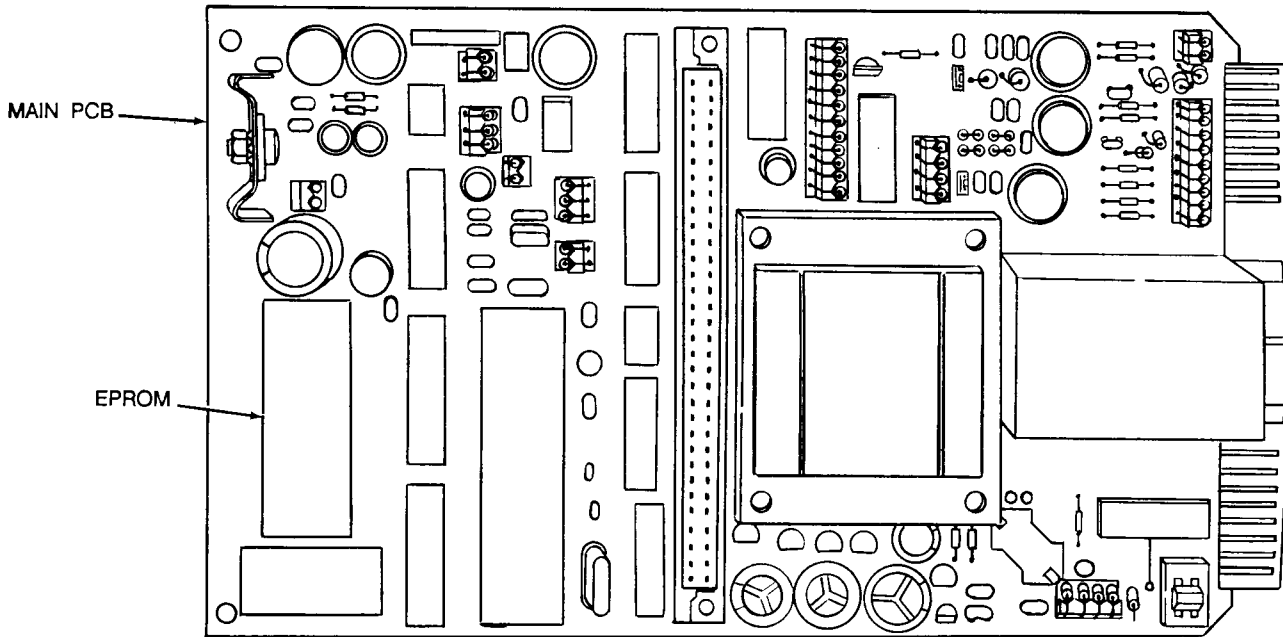

Figure 3-2. Main PCB (Model 218A) EPROM Replacement

3-4. MODEL TC200 VERITRIM ELECTRONICS

SETUP. Before beginning operation, it is important that the probe heater set point of the existing electronics be changed to support the World Class 3000 Probe. To convert the Model TC200 Electronics Package for use with the World Class 3000 Probe and Heater Power Supply, an EPROM change is necessary. The replacement EPROM needed is part number 1M03154G02.

a. EPROM Replacement. To replace the EPROM, proceed as follows:

1. Shut off and lock out power to the electronics package.

2. Open electronics enclosure.

3. On the main PCB, Figure 3-3, locate and remove old EPROMs U11 and U12.

4. Replace with new EPROMs (part number 1M03154G02) being careful to install U11 and U12 in their proper locations.

5. Close electronics enclosure and power up system.

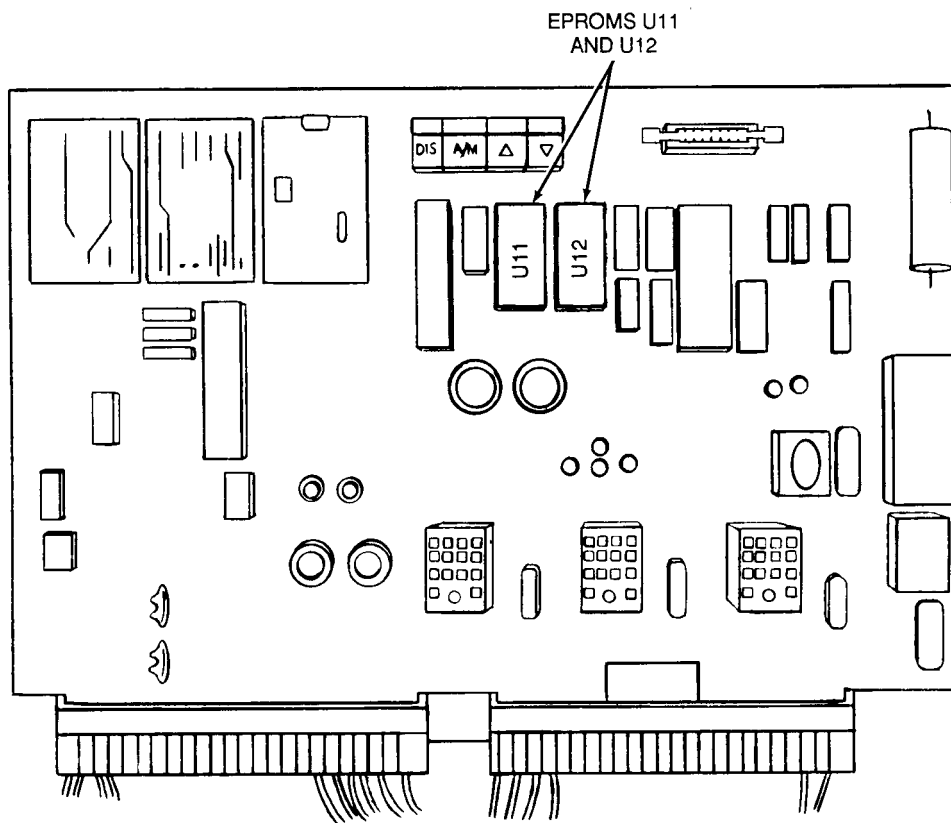

Figure 3-3. Main PCB (Model TC200) EPROM Replacement

b. **Heater Set Point Adjustment.** The adjustment procedure required for the Model TC200 Electronics Package is as follows:

1. Open keylocked enclosure to access membrane keyboard.
2. Put controller in PAR (parameter) mode by depressing "LOCK" "Σ" "%O₂" "INC" "ACK" in sequence.
3. Depress "ACK" pushbutton to clear display.
4. Press "NUM" pushbutton.
5. Using "INC", "DEC" buttons, display parameter 125.
6. Press "VAL" button.
7. Using "INC", "DEC" buttons, change parameter 125 value to 15.4.
8. Press "ENT" to save new value.

that the probe heater set point of the existing electronics be changed to support the World Class 3000 Probe. To convert the Model 132 Digital Electronics Package for use with the World Class 3000 Probe and Heater Power Supply, an EPROM change is necessary. The replacement EPROM needed is as identified below:

United States IM03222G01
 United Kingdom
 Germany
 France
 Italy

To replace the EPROM, proceed as follows:

- a. Shut off and lock out power to the electronics package.
- b. Open electronics enclosure.
- c. On the Main PCB, Figure 3-4, locate and remove old EPROM.
- d. Replace with new EPROM.
- e. Close electronics enclosure and power up system.

3-5. **MODEL 132 DIGITAL ELECTRONICS SETUP.** Before beginning operation, it is important

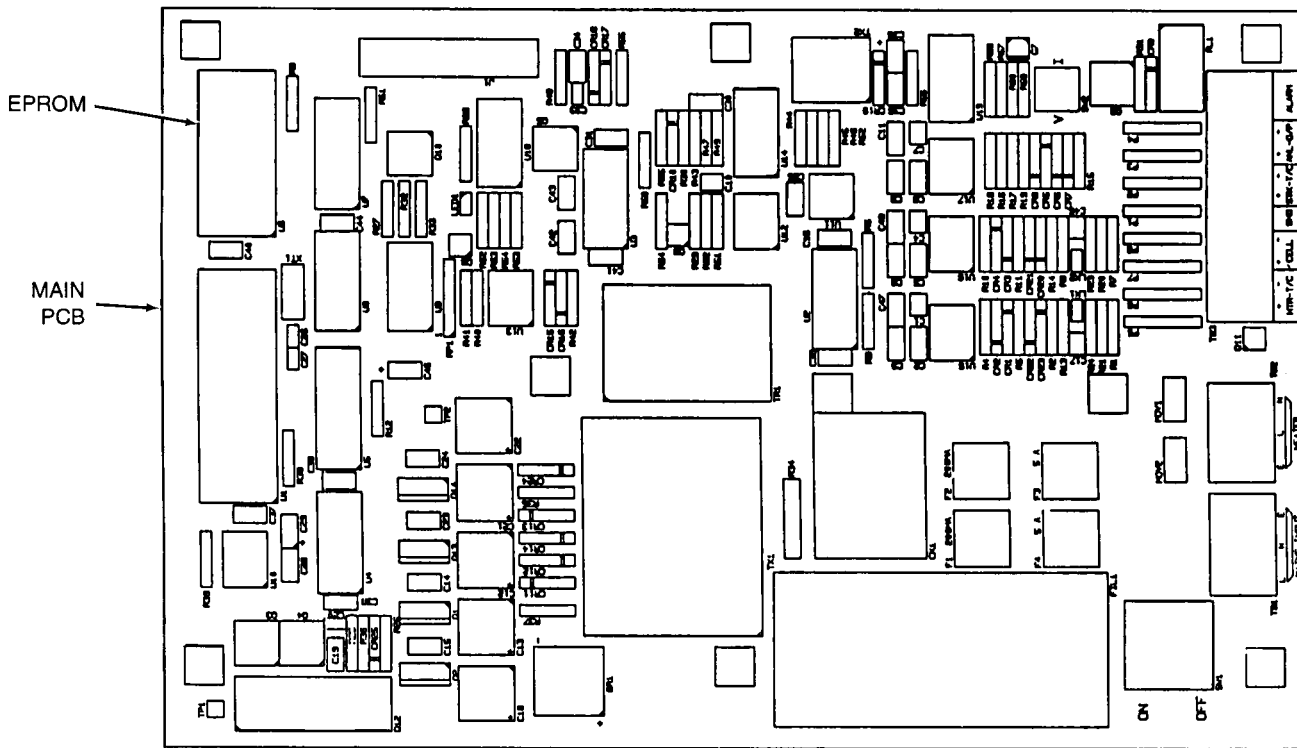

Figure 3-4. Main PCB (Model 132) EPROM Replacement

SECTION IV. TROUBLESHOOTING

- 4-1. **OVERVIEW.** Troubleshooting for the oxygen analyzer system is broken down to the main component level. Faults within the probe or heater power supply may cause symptoms which overlap.

WARNING

Install all protective equipment covers and safety ground leads after troubleshooting. Failure to replace covers and ground leads could result in serious injury or death.

- 4-2. **SYSTEM TROUBLESHOOTING.** Troubleshooting of individual components within the oxygen analyzer system are contained in the following.
- a. **World Class 3000 Probe.** Troubleshooting information for the World Class 3000 Probe is contained in Appendix A, Section II.

- b. **HPS 3000 Heater Power Supply.** Troubleshooting information for the HPS 3000 Heater Power Supply is contained in Appendix B, Section II.
- c. **Model 218 And 225 (Analog) Electronics Package.** Troubleshooting information for the Model 218 and 225 Electronics Package is contained in IB-106-101.
- d. **Model 218A Electronics Package.** Troubleshooting information for the Model 218 Electronics Package is contained in IB-106-101A.
- e. **TC200 Veritrim Electronics Package.** Troubleshooting information for the TC200 VeriTrim Electronics Package is contained in IB-107-020.
- f. **Model 132 Digital Electronics Package.** Troubleshooting information for the Model 132 Electronics Package is contained in IB 106-106A.

SECTION V. RETURNING EQUIPMENT TO THE FACTORY

5-1. If factory repair of defective equipment is required, proceed as follows:

- a.** Secure a return authorization number from a Rosemount Analytical Sales Office or Representative before returning the equipment. Equipment must be returned with complete identification in accordance with Rosemount instructions or it will not be accepted.

In no event will Rosemount be responsible for equipment returned without proper authorization and identification.

- b.** Carefully pack defective unit in a sturdy box with sufficient shock absorbing material to insure that no additional damage will occur during shipping.
- c.** In a cover letter, describe completely:
 - 1. The symptoms from which it was determined that the equipment is faulty.
 - 2. The environment in which the equipment has been operating (housing, weather, vibration, dust, etc.).
 - 3. Site from which equipment was removed.
 - 4. Whether warranty or nonwarranty service is requested.

5. Complete shipping instructions for return of equipment.

6. Reference the return authorization number.

- d.** Enclose a cover letter and purchase order and ship the defective equipment according to instructions provided in Rosemount Return Authorization, prepaid, to:

Rosemount Analytical Inc.
RMR Department
1201 N. Main Street
Orrville, Ohio 44667

If warranty service is requested, the defective unit will be carefully inspected and tested at the factory. If failure was due to conditions listed in the standard Rosemount warranty, the defective unit will be repaired or replaced at Rosemount's option, and an operating unit will be returned to the customer in accordance with shipping instructions furnished in the cover letter.

For equipment no longer under warranty, the equipment will be repaired at the factory and returned as directed by the purchase order and shipping instructions.

INDEX

This index is an alphabetized listing of parts, terms, and procedures having to do with the World Class 3000 Oxygen Analyzer with HPS 3000 Heater Power Supply. Every item listed in the index refers to a location in the manual by page number or numbers.

A

Abrasive Shield, 2-1
Absolute Temperature, 1-2
Adapter Plate, 2-1
Ambient Temperature, 2-7
Arithmetic Constant, 1-2

C

Cell Constant, 1-2
Ceramic Filter, 2-1
Check Valve, 1-3

D

Dust Seal Packings, 2-1

E

Electrochemical Cell, 1-2
Electronic Packages, 1-1
EPROM, 3-3
Explosion-Proof Enclosure, 1-2

F

Fuses, 2-7, 2-10

G

Gas Stratification, 2-1

H

Heater Power Supply, 1-1
Hub Grooves, 2-1

I

Instrument Air, 1-3
In Situ, 1-2

M

Model 218 Electronics Package, 3-1
Model 218A Digital Electronic Package, 3-2

M

Model 132 Digital Electronics Package, 3-4
Model 225 Electronics Package, 3-1
Model TC200 VERITRIM Electronics Package, 3-3
Mother Board, 2-9
Mounting Adapter Plate, 1-1

N

NEMA 4X Enclosure, 2-7
Nernst Equation, 1-2

O

Orsat Apparatus, 1-2
Oxygen Analyzer, 1-1
Oxygen Ions, 1-2

P

Probe Heater Setpoint, 3-1, 3-2, 3-3

R

Reference Gas, 1-3

S

Sampling System, 1-1
Sensing Point, 2-1
Sensor Cell, 1-2
Solenoid Valve, 1-3

T

Transformer, 1-2

V

Vee Deflector, 2-1

W

Water Vapor, 1-2

Z

Zirconia Disc, 1-2

**APPENDIX A, REV. 3.6
WORLD CLASS 3000
OXYGEN ANALYZER
(PROBE)**

Instruction Bulletin IB-106-300N SERIES

HIGHLIGHTS OF CHANGES

Effective May, 1996 Rev. 3

PAGE	SUMMARY
--	General. Updated appendix to reflect probe design changes.
1-10	Added "Extended temperature by-pass arrangements" to Figure 1-13, Sheet 3 of 3.

Effective June, 1996 Rev. 3.1

PAGE	SUMMARY
1-10	Updated part ordering information.

Effective August, 1996 Rev. 3.2

PAGE	SUMMARY
4-1	Updated cell replacement kit part numbers for the probe.

Effective October, 1996 Rev. 3.3

PAGE	SUMMARY
1-5	Added NOTE to Figure 1-7.

Effective January, 1997 Rev. 3.4

PAGE	SUMMARY
1-1	Added warning to read new safety instructions.
2-1	Added protective covers and grounds warning.
3-1	Added protective covers and grounds warning.

Effective February, 1998 Rev. 3.5

PAGE	SUMMARY
3-3	Changed screw torque in paragraph 3-3 h.

Effective July, 1998 Rev. 3.6

PAGE	SUMMARY
--	Changed test gas to calibration gas and reference gas to reference air throughout the appendix.

TABLE OF CONTENTS

Section	Page
I. DESCRIPTION	1-1
1-1. Oxygen Analyzer (Probe) - General	1-1
1-2. Probe Assembly Exterior	1-1
1-3. Inner Probe Assembly	1-3
1-4. Probe Junction Box	1-4
1-5. Cable Assembly	1-4
1-6. Probe Options	1-4
II. PROBE TROUBLESHOOTING	2-1
2-1. Overview	2-1
2-2. Probe Troubleshooting	2-1
III. SERVICE AND NORMAL MAINTENANCE	3-1
3-1. Overview	3-1
3-2. Probe Recalibration	3-1
3-3. Cell Replacement	3-1
3-4. Optional Ceramic Diffusion Element Replacement	3-3
3-5. Replacement of Contact and Thermocouple Assembly	3-5
3-6. Replacement of Heater, V-Strut and Backplate Assembly	3-6
3-7. Calibration Gas and Reference Air Lines For High Temperature - Corrosive Environment Operation	3-8
IV. REPLACEMENT PARTS	4-1

LIST OF ILLUSTRATIONS

Figure	Page
1-1. Oxygen Analyzer (Probe) Exploded View	1-0
1-2. Main Probe Components	1-1
1-3. Cell and Tube Assemblies	1-2
1-4. Optional Ceramic Diffusor and Vee Deflector Assembly	1-2
1-5. Inner Probe Assembly	1-3
1-6. Probe Junction Box	1-4
1-7. Abrasive Shield Assembly	1-5
1-8. Ceramic Diffusion/Dust Seal Assembly	1-6
1-9. Flame Arrestor Diffusion/Dust Seal Assembly	1-6
1-10. Ceramic Diffusion Assembly	1-6
1-11. Flame Arrestor Diffusion Assembly	1-6
1-12. Snubber Diffusion/Dust Seal Assembly	1-7
1-13. Bypass Probe Option	1-8
2-1. Flowchart of Probe Related Problems, #1	2-3
2-2. Flowchart of Probe Related Problems, #2	2-4
3-1. Cell Wiring Connection	3-2
3-2. Removal of Optional Diffusor and Vee Deflector	3-3
3-3. Cell Replacement Kit	3-3
3-4. Probe Junction Box Mechanical Connections	3-5
3-5. Inner Probe Replacement (Heater, V-Strut, and Backplate Assembly)	3-5
3-6. Heater, Strut, and Backplate Assembly (Inner Probe Assembly)	3-6
3-7. Oxygen Analyzer (Probe), Cross-Sectional View	3-7
3-8. High Temperature - Corrosive Environment Kit	3-8

NOTE: NOT ALL PARTS SHOWN ARE AVAILABLE FOR PURCHASE SEPARATELY. FOR LIST OF AVAILABLE PARTS, SEE TABLE 4-1.

1. Heater, Strut, and Backplate Assembly
2. Diffusion Assembly
3. Retainer Screw
4. Cell and Flange Assembly
5. Corrugated Seal
6. Probe Tube Assembly
7. Screw
8. Washer
9. Cover Chain Screw
10. Cover Chain
11. Probe Junction Box Cover
12. Cover Gasket
13. Wiring Diagram
14. O-Ring
15. Terminal Block Screws
16. Terminal Block
17. Terminal Block Marker
18. Terminal Block Mounting Plate

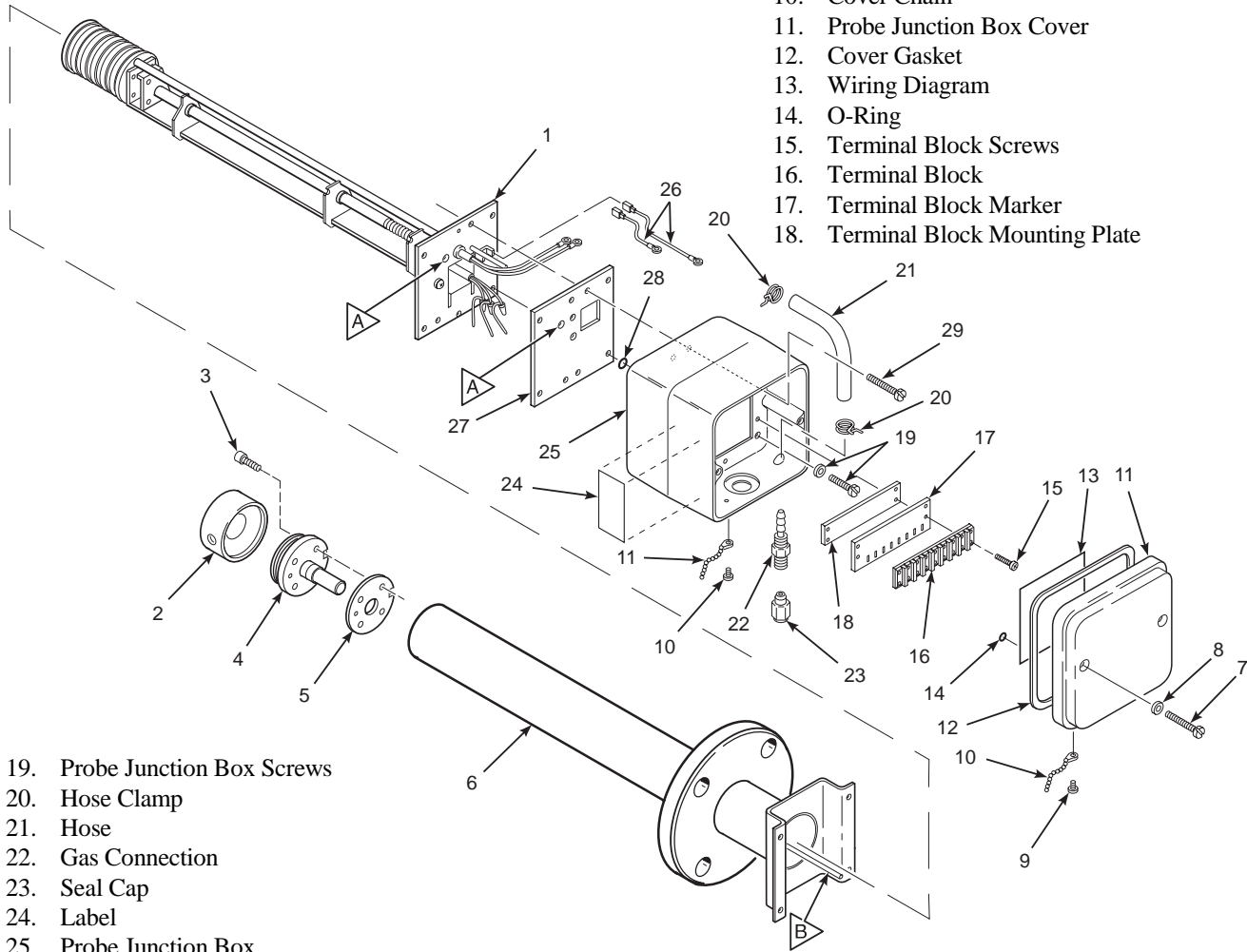

19. Probe Junction Box Screws
20. Hose Clamp
21. Hose
22. Gas Connection
23. Seal Cap
24. Label
25. Probe Junction Box
26. Ground Wires
27. Insulating Gasket
28. Washer
29. Screw

NOTE: ITEM **B**, CALIBRATION GAS TUBE, FITS INTO HOLES **A** WHEN PROBE IS ASSEMBLED.

21240005

Figure 1-1. Oxygen Analyzer (Probe) Exploded View

SECTION I. DESCRIPTION

WARNING

Read the "Safety instructions for the wiring and installation of this apparatus" at the front of this Instruction Bulletin. Failure to follow the safety instructions could result in serious injury or death.

- 1-1. **OXYGEN ANALYZER (PROBE) - GENERAL.** The Oxygen Analyzer (Probe), Figure 1-1, consists of three component groups: probe exterior, inner probe, and probe junction box, Figure 1-2.

- 1-2. **PROBE ASSEMBLY EXTERIOR.** Primary probe exterior components include a flange-mounted zirconium oxide cell, mounted on a tube assembly and protected by a snubber diffusion assembly.
- a. **Cell and Flange Assembly.** The primary component in the cell and flange assembly, Figure 1-3, is a yttria-stabilized zirconium oxide cell. It creates an electrical signal when the oxygen level on one side is out of balance with the oxygen level on the other side. This signal is proportional to the difference in oxygen levels.
- b. **Probe Tube Assembly.** Four screws secure the cell and flange assembly, Figure 1-3, to the probe tube assembly. When in place, the cell is inside the tube.

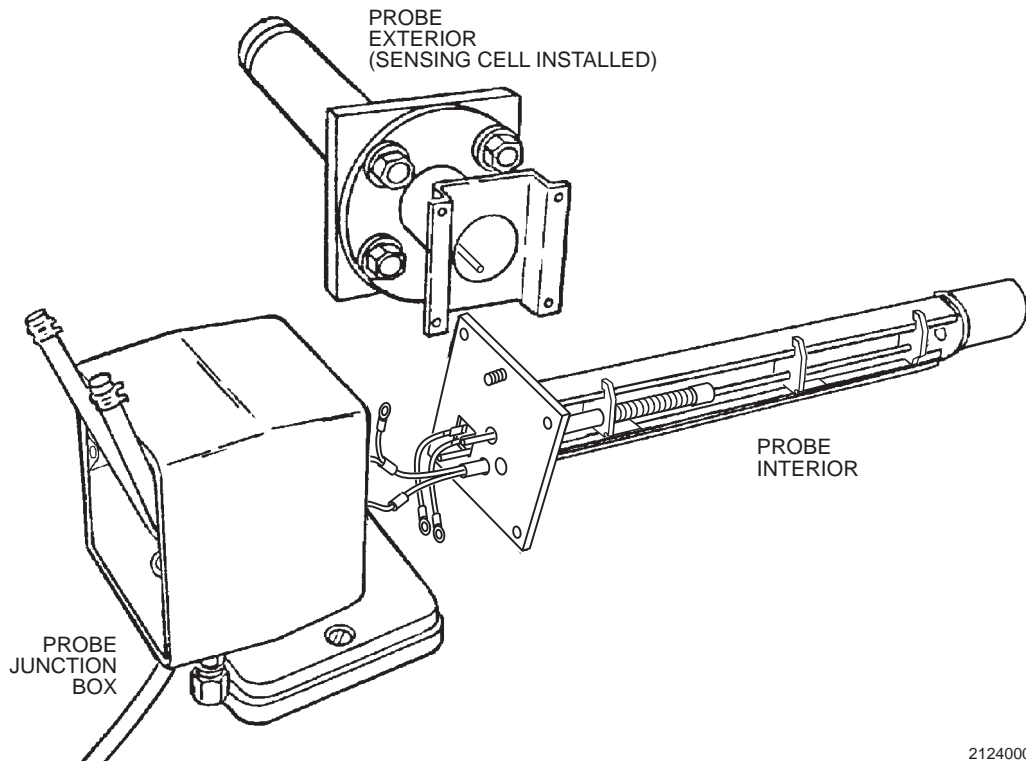

21240006

Figure 1-2. Main Probe Components

Table 1-1. Specifications for Oxygen Analyzing Equipment.^{1,2}

Probe lengths, nominal	18 inches (457 mm), 3 feet (0.91 m), 6 feet (1.83 m), 9 feet (2.74 m), or 12 feet (3.66 m), depending on duct dimensions
Temperature limits in process measurement area	50° to 1300°F (10° to 704°C)
Standard/current output	4-20 mA dc signal (factory set)
O ₂ indication (Digital display and analog output)	0.1% O ₂ or ±3% of reading, whichever is greater using Rosemount calibration gases
System speed of response	less than 3 seconds (amplifier output)
Resolution sensitivity	0.01% O ₂ transmitted signal
HPS 3000 housing	NEMA 4X (IP56)
Probe reference air flow	2 scfh (56.6 L/hr) clean, dry, instrument quality air (20.95% O ₂), regulated to 5 psi (34 kPa)
Calibration gas mixtures	Rosemount Hagan Calibration Gas Kit Part No. 6296A27G01 contains 0.4% O ₂ N ₂ Nominal and 8% O ₂ N ₂ Nominal
Calibration gas flow	5 scfh (141.6 L/hr)
HPS 3000 Power supply	100/110/220 ±10% Vac at 50/60 Hz
HPS 3000 Power requirement	200 VA
HPS 3000 Ambient Operating Temperature	32° to 120°F (0° to 50°C)
Ambient operating temperature (Probe Junction Box)	300°F (150°C) max
Approximate shipping weights:	
18 inch (457 mm) package	55 pounds (24.97 kg)
3 foot (0.91 m) package	60 pounds (27.24 kg)
6 foot (1.83 m) package	65 pounds (29.51 kg)
9 foot (2.74 m) package	72 pounds (32.66 kg)
12 foot (3.66 m) package	78 pounds (35.38 kg)

¹ All static performance characteristics are with operating variables constant.

² Equipment ordered utilizing this document as reference will be supplied to the USA standard design. Customers requiring the EEC standard design should request the EEC documentation and utilize its ordering data. Temperatures over 1000°F (537°C) may affect the ease of field cell replaceability.

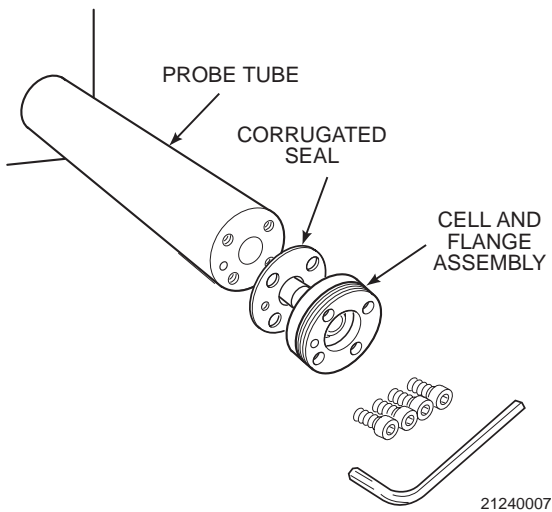

Figure 1-3. Cell and Tube Assemblies

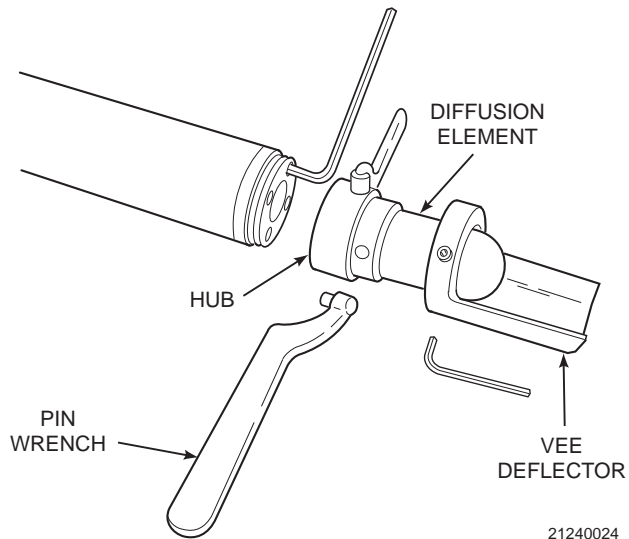

Figure 1-4. Optional Ceramic Diffusor and Vee Deflector Assembly

The tube assembly includes a flange which mates with a stack-mounted flange (shown attached to the probe flange in Figure 1-2). Studs on the stack flange make installation easy. There is also a tube to carry calibration gas from the probe junction box to the process side of the cell during calibration.

- c. **Snubber Diffusion Assembly.** The snubber diffusion assembly protects the cell from heavy particles and isolates the cell from changes in temperature. The snubber diffusion assembly threads onto the cell and flange assembly. Pin spanner wrenches (probe disassembly kit 3535B42G01) are applied to holes in the snubber diffusion element hub to remove or install the snubber diffusion assembly.

An optional ceramic diffuser element and vee deflector, shown in Figure 1-4, is available. The ceramic diffuser assembly is also available in a flame arresting version to keep heat from the cell from igniting flue gases.

Systems that use an abrasive shield require a special snubber diffusion assembly with a hub that is grooved to accept two dust seal gaskets. This special diffuser is available in both snubber and ceramic versions. See Probe Options, section 1-6.

- d. **Cell - General.** The components which make up the cell are machined to close tolerances and assembled with care to provide accurate oxygen measurements. Any replacement requires attention to detail and care in assembly to provide good results.

WARNING

Failure to follow the instructions in this manual could cause danger to personnel and equipment. Read and follow instructions in this manual carefully.

The oxygen probe includes an inner electrode for the cell assembly. It consists of a platinum pad and a platinum/inconel composite wire which produces the cell constant offset voltage described in the Nernst equation.

With this pad and wire, the constant will be between -10 and +15 mV. The cell constant is noted in the calibration data sheet supplied with each probe.

Every probe should be calibrated and checked after repair or replacement of cell, pad and wire, heater, and thermocouple, or after disassembly of the probe.

1-3. INNER PROBE ASSEMBLY. The inner probe assembly, Figure 1-5, consists of six main parts:

- a. Ceramic support rod with four holes running through the length. The holes serve as insulated paths for the cell signal wire and thermocouple wires.
- b. A heater that is helically wrapped on a quartz support cylinder and insulated.
- c. A chromel-alumel thermocouple which acts as the sensing element for the temperature controller. (Not visible in Figure 1-5; located within ceramic support rod.)
- d. A platinum screen pad which forms electrical contact with the inner electrode of the electrochemical cell. (Not visible in Figure 1-5; located at end of ceramic support rod.) The pad is attached to an inconel wire which carries the signal to the terminal strip.
- e. A V-strut assembly to give support to the inner probe assembly.
- f. A tube to carry reference air to the cell.

Turn to Section III, Service and Normal Maintenance, for repair procedures for probe components.

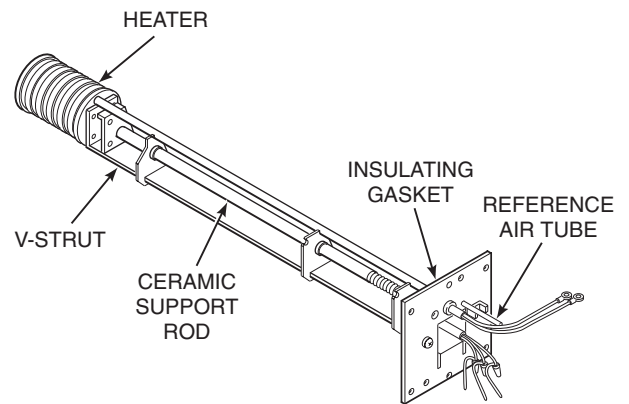

27270015

Figure 1-5. Inner Probe Assembly

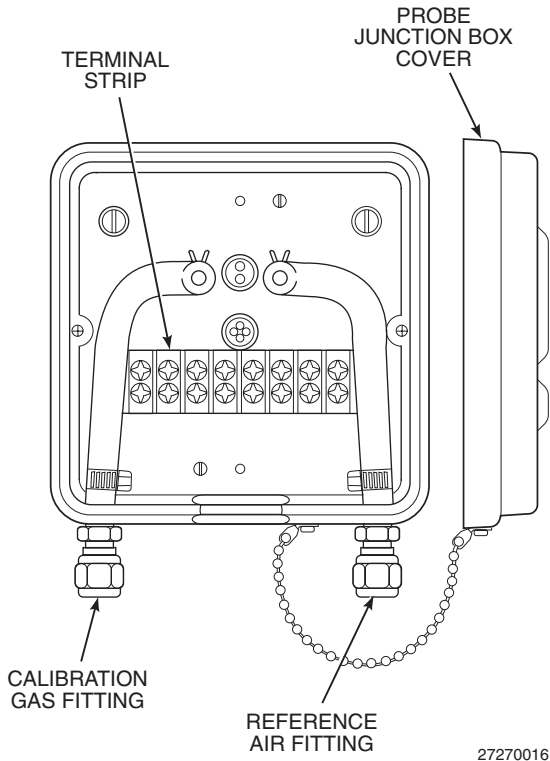

Figure 1-6. Probe Junction Box

1-4. PROBE JUNCTION BOX. The probe junction box, Figure 1-6, is positioned at the external end of the probe and contains a terminal strip for electrical connections and fittings for reference air and calibration gases. Fittings are for 0.250 inch stainless steel tubing on American units and 6 mm on European units. The calibration fitting has a seal cap which must remain in place except during calibration. A tubing fitting is also supplied to be used with the calibration gas supply during calibration.

If the calibration gas bottles will be permanently hooked up to the probe, a manual block valve is required at the probe (between the calibration fitting and the gas line) to prevent condensation of flue gas down the calibration gas line.

During operation and calibration, reference air is supplied through the reference air fitting to the reference side of the cell. This gives the system a known quantity of oxygen with which to compare the oxygen level in the process gas. Though ambient air

can be used for this purpose, accuracy can only be assured if a reference air set is used.

During calibration, two gases of different known oxygen concentrations are injected one at a time through the calibration gas fitting. Stainless steel tubing delivers this gas to the process side of the cell. In a healthy cell, the difference in oxygen pressure from the process side to the reference side of the cell will cause a millivolt output proportional to the difference in oxygen levels. The electronics unit can use the two millivolt outputs caused by the two calibration gases for either automatic or semi-automatic calibration.

CAUTION

Do not attempt to remove a process gas sample through either gas fitting. Hot gases from the process would damage gas hoses in the probe junction box.

1-5. CABLE ASSEMBLY. The system uses a 7-conductor cable to connect the probe to the electronics package. Standard length for this cable is 20 feet (6 m), but lengths up to 150 feet (45 m) are available. The seven conductors include one shielded pair of wires for the cell millivolt signal, one shielded pair of type K wires for the thermocouple, and three individual 16-gauge wires for the heater and for ground. The assembled conductors are wrapped by a type K Teflon™ jacket and braided stainless steel shield. The Teflon™ and stainless steel jacketing is suitable for high temperature use. All metal shields are isolated at the probe end and connect by drain wires to ground at the electronics.

1-6. PROBE OPTIONS.

a. Abrasive Shield Assembly. The abrasive shield assembly, Figure 1-7, is a stainless-steel tube that surrounds the probe assembly. The shield protects the probe against particle abrasion and corrosive condensations, provides a guide for ease of insertion, and acts as a probe position support, especially for longer length probes. The abrasive shield assembly uses a modified diffusor and vee deflector assembly, fitted with dual dust seal packing.

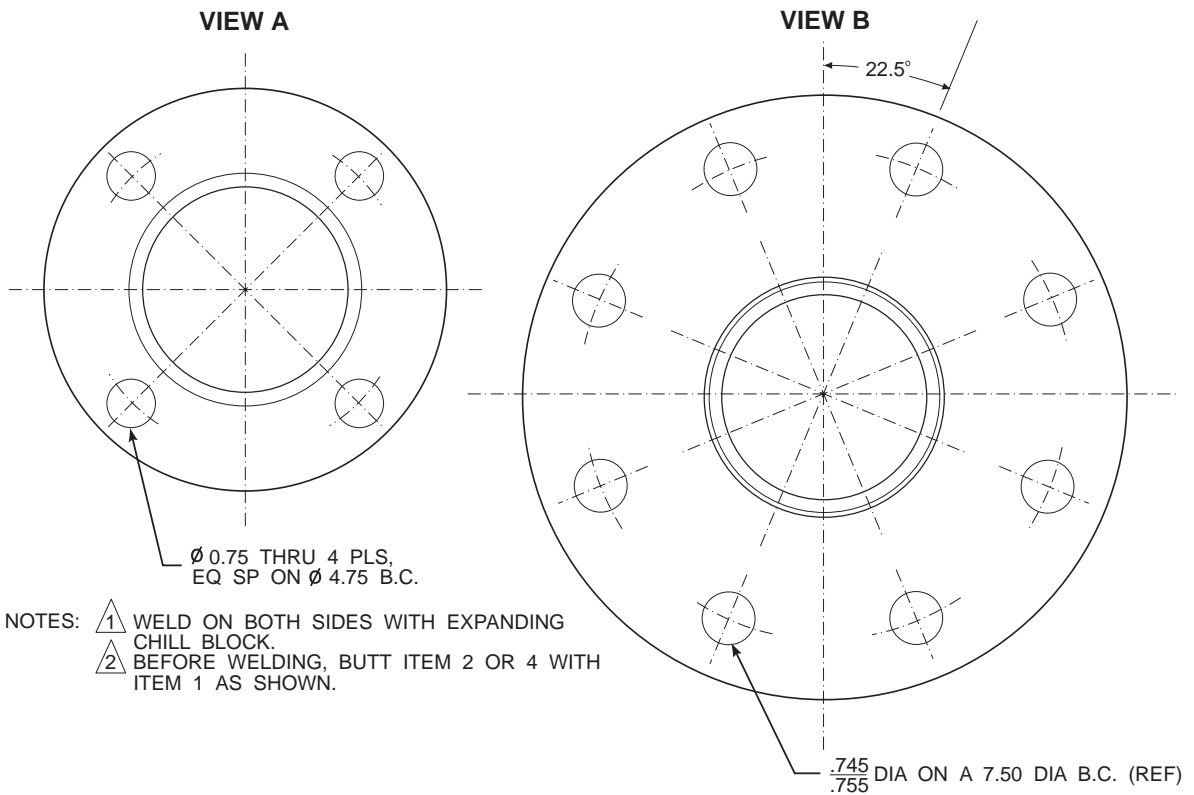
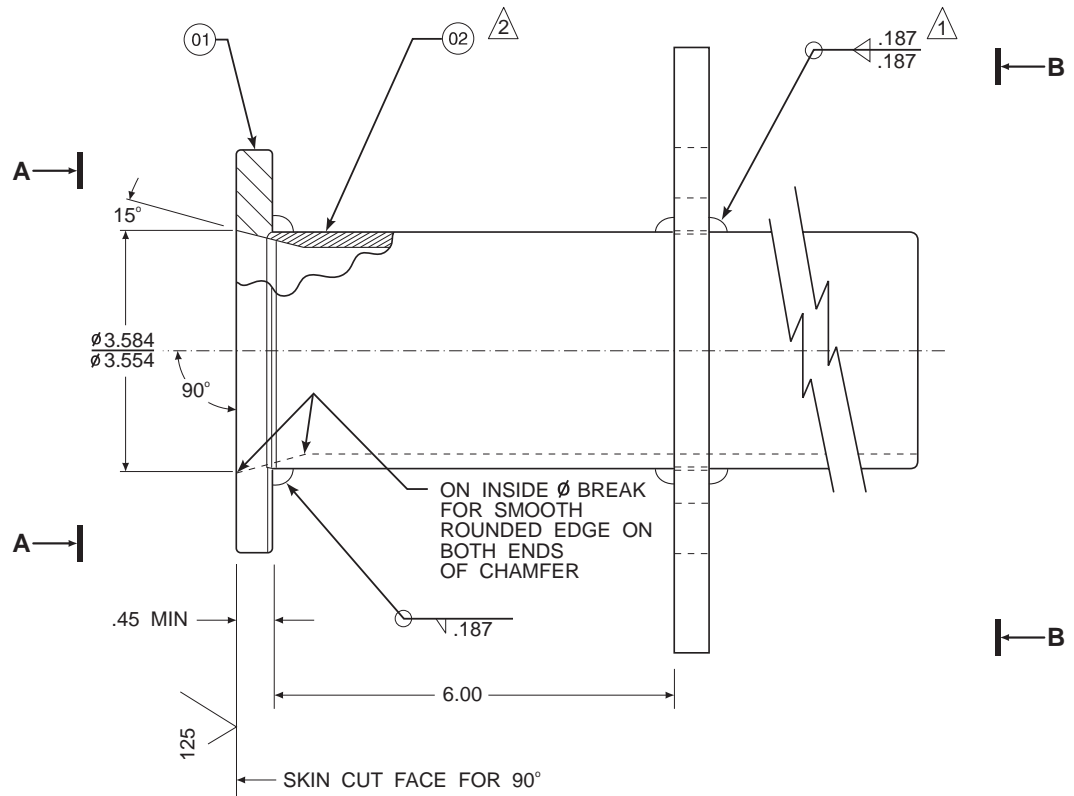
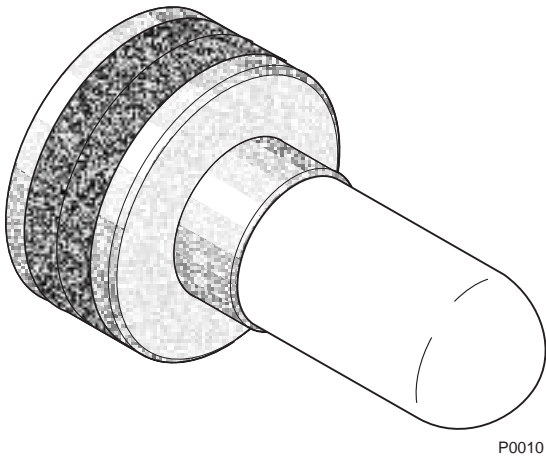

Figure 1-7. Abrasive Shield Assembly

16860033

NOTE

In highly abrasive applications, rotate the shield 90 degrees at normal service intervals to present a new wear surface to the abrasive flow stream.



P0010

Figure 1-8. Ceramic Diffusion/Dust Seal Assembly

These modified diffusion and vee deflector assemblies are available in standard, Figure 1-8, and flame arrester version, Figure 1-9.

- b. **Ceramic Diffusion Assembly.** The ceramic diffusion assembly, Figure 1-10, is the traditional design for the probe. Used for over 25 years, the ceramic diffusion assembly provides a greater filter surface area for the probe.

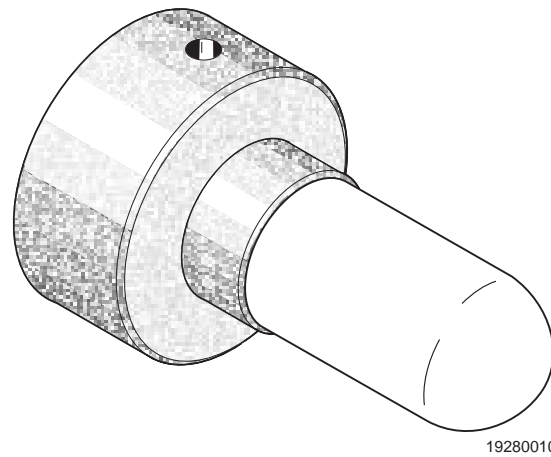

19280010

Figure 1-10. Ceramic Diffusion Assembly

- c. **Flame Arrester Diffusion Assembly.** Where a high concentration of unburned fuel is present in the exhaust gases, a flame arrester diffusion assembly, Figures 1-9 and 1-11 is recommended.

The flame diffusion assembly includes a set of baffles between the cell and the stack gases. This keeps 1500°F (816°C) cell temperatures from igniting unburned fuel in the stack.

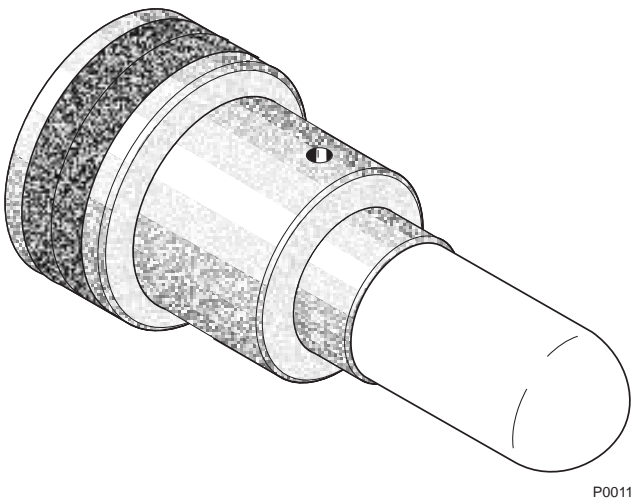

P0011

Figure 1-9. Flame Arrester Diffusion/Dust Seal Assembly

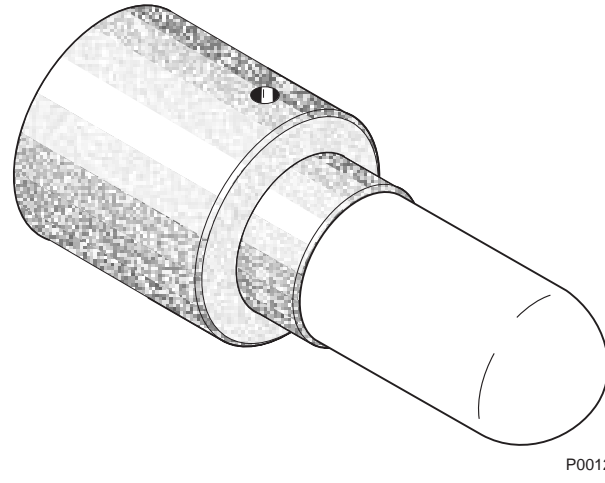

P0012

Figure 1-11. Flame Arrester Diffusion Assembly



Figure 1-12. Snubber Diffusion/Dust Seal Assembly

- d. **Snubber Diffusion/Dust Seal Assembly.** The snubber diffusion/dust seal assembly, Figure 1-12, is used in applications where an abrasive shield is to be used with a snubber type diffusion element. The dust seal consists of two rings of packing to prevent abrasive dust from collecting inside the abrasive shield.
- e. **Bypass Probe Options.** For processes where the flue gas exceeds the maximum allowable temperature of 1300°F (704°C) a bypass sensor package can be employed. The bypass system uses

an 18 inch (457 mm) or 3 foot (0.92 m) probe mounted externally on the stack or duct. The process or exhaust gases are directed out to the probe through a passive sampling system using inconel tubes. Flue gas flow induces the movement of gases into, through, and out of the bypass unit. The bypass arrangement does not require the use of aspiration air and the gas which flows past the probe is returned to the stack or duct.

The bypass probe package is normally used for process temperatures of 1300°F (704°C) to 2000°F (1094°C). A higher temperature version of the bypass provides for operation at temperatures up to 2500°F (1372°C). In this version the pick up tubes are made of a special high-temperature alloy.

Overall dimensions and mounting details of the American and European bypass systems are shown in Figure 1-13.

- f. **Probe Mounting Jacket Options.** A probe mounting jacket option is available to allow the probe to operate at temperatures of up to 2000°F (1095°C). A separate instruction bulletin is available for this option.

- NOTES:
1. REFERENCE AIR SUPPLY CONNECTION BITE TYPE FITTING (PARKER CPI) FOR 0.250 O.D. TUBING. 2 SCFH AT 3 PSIG MAX. CLEAN DRY AIR REQUIRED. FITTING IS LOCATED ON FAR SIDE.
 2. CALIBRATION AND PURGE GAS CONNECTION. BITE TYPE FITTING (PARKER CPI) 10 SCFH AT 32 PSIG MAX. CALIBRATION GAS REQUIRED.
 3. LAG TO ENSURE GAS TEMPERATURE DOES NOT GO BELOW DEW POINT OR EXCEED 500°C.
 4. INSTALL WITH ANALYZER IN A VERTICALLY DOWNWARDS DIRECTION ONLY.
 5. FLUE GAS OPERATING TEMPERATURE RANGE 1200° TO 1800°F (650° TO 980°C).
 6. RECOMMENDED TWO INCH THK INSULATION. THERMAL CONDUCTIVITY K EQUALS 0.5 FOR INSULATION.
 7. DIMENSIONS ARE IN INCHES WITH MILLIMETERS IN PARENTHESES.

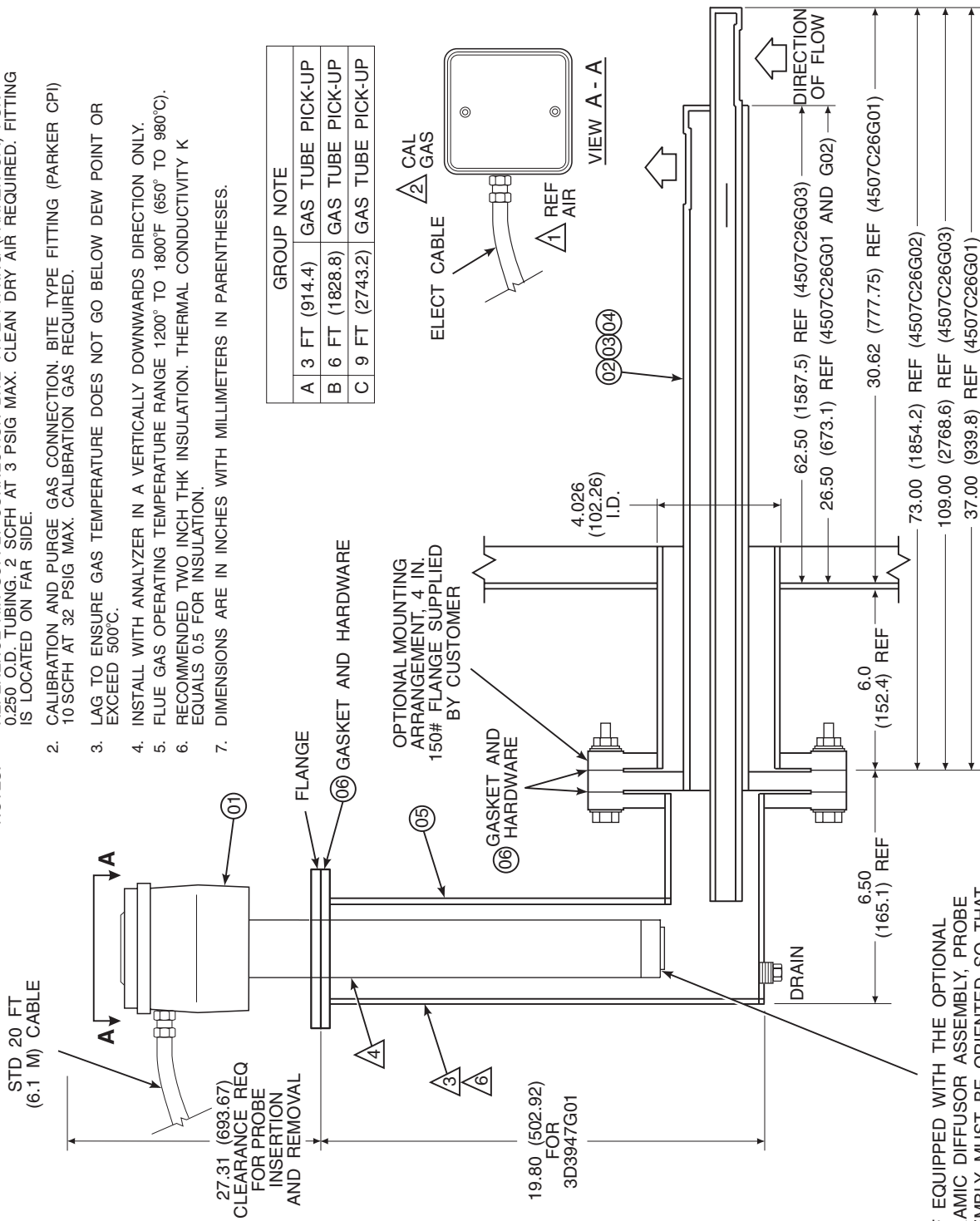

IF EQUIPPED WITH THE OPTIONAL CERAMIC DIFFUSOR ASSEMBLY, PROBE ASSEMBLY MUST BE ORIENTED SO THAT VEE SHIELD IS SQUARE TO GAS FLOW.

Figure 1-13. Bypass Probe Option (Sheet 1 of 3)

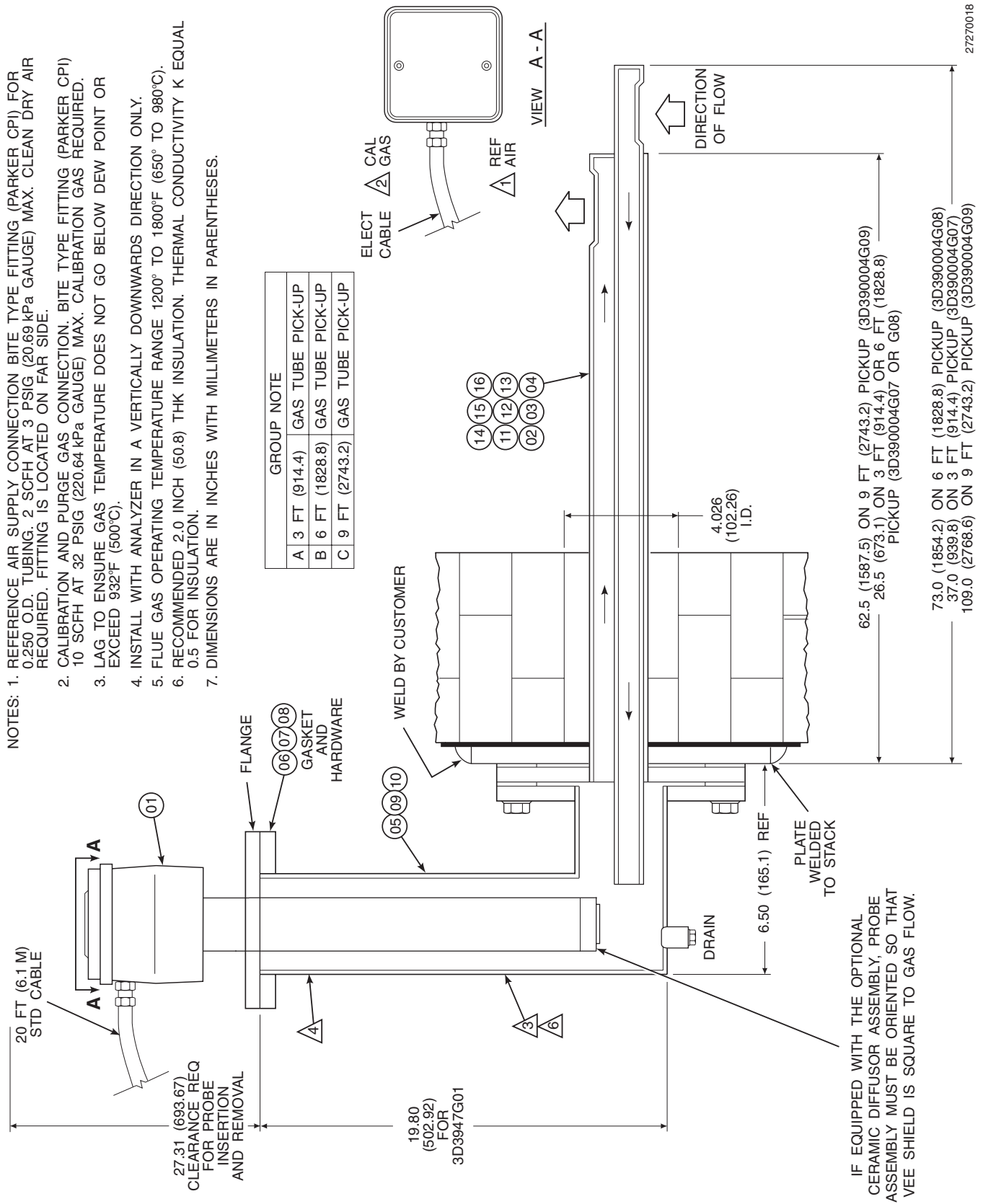

Figure 1-13. Bypass Probe Option (Sheet 2 of 3)

PARTS LIST				FLANGE STYLE				ANSI			JIS			DIN		
				GROUP NOTE	A	B	C	A	B	C	A	B	C			
NOTE	PART NAME	DEFINER	PARTS LIST UNITS: INCHES	MAIL CODE PART NUMBER OR REF DWG	3D39004 GROUP											
ITEM					SIZE-REFERENCE INFORMATION	G01	G02	G03	G04	G05	G06	G07	G08	G09		
01	WORLD CLASS 3000	DWG	PROBE 18 IN.	ORDER FROM MATRIX												
02	GAS PICK-UP	DWG	3 FT	4507C26G01	1											
03	GAS PICK-UP	DWG	6 FT	4507C26G02		1										
04	GAS PICK-UP	DWG	9 FT	4507C26G03			1									
05	ANALYZER HOUSING	DWG	FOR WORLD CLASS 3000 ANSI	3D39005G01	1	1	1									
06	MTG HARDWARE	DWG	FOR ANSI FLANGE	3535B58G01	1	1	1									
07	MTG HARDWARE	DWG	FOR JIS	3535B58G03				1	1	1						
08	MTG HARDWARE	DWG	FOR DIN	3535B58G05								1	1	1		
09	ANALYZER HOUSING	DWG	FOR JIS	3D39005G02				1	1	1						
10	ANALYZER HOUSING	DWG	FOR DIN	3D39005G03								1	1	1		
11	GAS PICK-UP	DWG	FOR JIS 3 FT	4507C26G04				1								
12	GAS PICK-UP	DWG	FOR JIS 6 FT	4507C26G05					1							
13	GAS PICK-UP	DWG	FOR JIS 9 FT	4507C26G06						1						
14	GAS PICK-UP	DWG	FOR DIN 3 FT	4507C26G07									1			
15	GAS PICK-UP	DWG	FOR DIN 6 FT	4507C26G08										1		
16	GAS PICK-UP	DWG	FOR DIN 9 FT	4507C26G09											1	

Extended Temperature By-Pass Arrangements (2400°F; 1300°C)

PART NO.	GROUP CODE	DESCRIPTION
1U0571	G01	3' By-pass Package with ANSI bolt pattern.
1U0571	G02	6' By-pass Package with ANSI bolt pattern.
1U0571	G03	9' By-pass Package with ANSI bolt pattern.
1U0571	G04	3' By-pass Package with JIS bolt pattern.
1U0571	G05	6' By-pass Package with JIS bolt pattern.
1U0571	G06	9' By-pass Package with JIS bolt pattern.
1U0571	G07	3' By-pass Package with DIN bolt pattern.
1U0571	G08	6' By-pass Package with DIN bolt pattern.
1U0571	G09	9' By-pass Package with DIN bolt pattern.

Figure 1-13. Bypass Probe Option (Sheet 3 of 3)

SECTION II. PROBE TROUBLESHOOTING

2-1. **OVERVIEW.** The probe troubleshooting section describes how to identify and isolate faults which may develop in the probe assembly.

WARNING

Install all protective equipment covers and safety ground leads after troubleshooting. Failure to replace covers and ground leads could result in serious injury or death.

2-2. **PROBE TROUBLESHOOTING.**

a. **Probe Faults.** Listed below are the four symptoms of probe failure.

1. The system does not respond to changes in the oxygen concentration.

2. The system responds to oxygen changes but does not give the correct indication.

3. The system does not give an acceptable indication of the value of the oxygen calibration gas being applied during calibration.

4. The system takes a long time to return to the flue gas value after the calibration gas is turned off.

b. Table 2-1 provides a guide to fault finding for the above symptoms.

c. Figures 2-1 and 2-2 provide an alternate approach to finding probe related problems.

Table 2-1. Fault Finding.

SYMPTOM	CHECK	FAULT	REMEDY
1. No response to oxygen concentration change when: Heater is cold and TC mV output is less than set point	Thermocouple continuity	Thermocouple failure	Replace thermocouple or return probe to Rosemount.
	Heater cold resistance to be 11 ohm to 14 ohm	Heater failure	Replace heater or return probe to Rosemount.
	Triac O/P to heater	Failure of electronics	Check HPS and electronics package.
	Recorder chart	Recorder failure	See Recorder Instruction Manual.
Heater is hot and T/C mV output is at set point ± 0.2 mV	Cell mV input to electronics <u>and</u> cell mV at probe junction box	No cell mV at probe when calibration gas applied	Replace cell or return probe to Rosemount.
		Probe cell mV OK but no input to electronics	Check out cable connection.
		Cell mV satisfactory both at probe junction box and input to electronics - failure of electronics	Check electronics package.

Table 2-1. Fault Finding (Continued).

SYMPTOM	CHECK	FAULT	REMEDY
<p>2. System responds to oxygen concentration changes <u>but</u> does not give correct indication</p> <p>Good response, with incorrect indication</p>	<p>Recorder or remote indicator</p> <p>System calibration</p> <p>Probe mounting and condition of duct</p> <p>Cell mV input to electronics</p>	<p>Calibration error</p> <p>Calibration error</p> <p>Air ingress into duct</p> <p>Failure of electronics</p>	<p>Recalibrate recorder or indicator. Reference Recorder Instruction Manual.</p> <p>Recalibrate system.</p> <p>Stop air leaks or resite probe.</p> <p>Check electronics package.</p>
<p>3. System does not give accurate indication of applied calibration gas</p>	<p>Calibration gas input port</p> <p>Ceramic diffusion element</p>	<p>Blocked port</p> <p>Diffusion element cracked, broken, or missing</p>	<p>Clean port. If the flue gas is condensing in the calibration gas line, insulate the back of the probe. Make sure that the calibration gas line is capped between calibrations, or a check valve is installed.</p> <p>Replace diffusion element.</p>
<p>4. System takes a long time to return to flue gas value after calibration gas is turned off</p>	<p>Diffusion element</p>	<p>Plugged diffusion element</p>	<p>Change diffusion element or snubber diffusion element.</p>

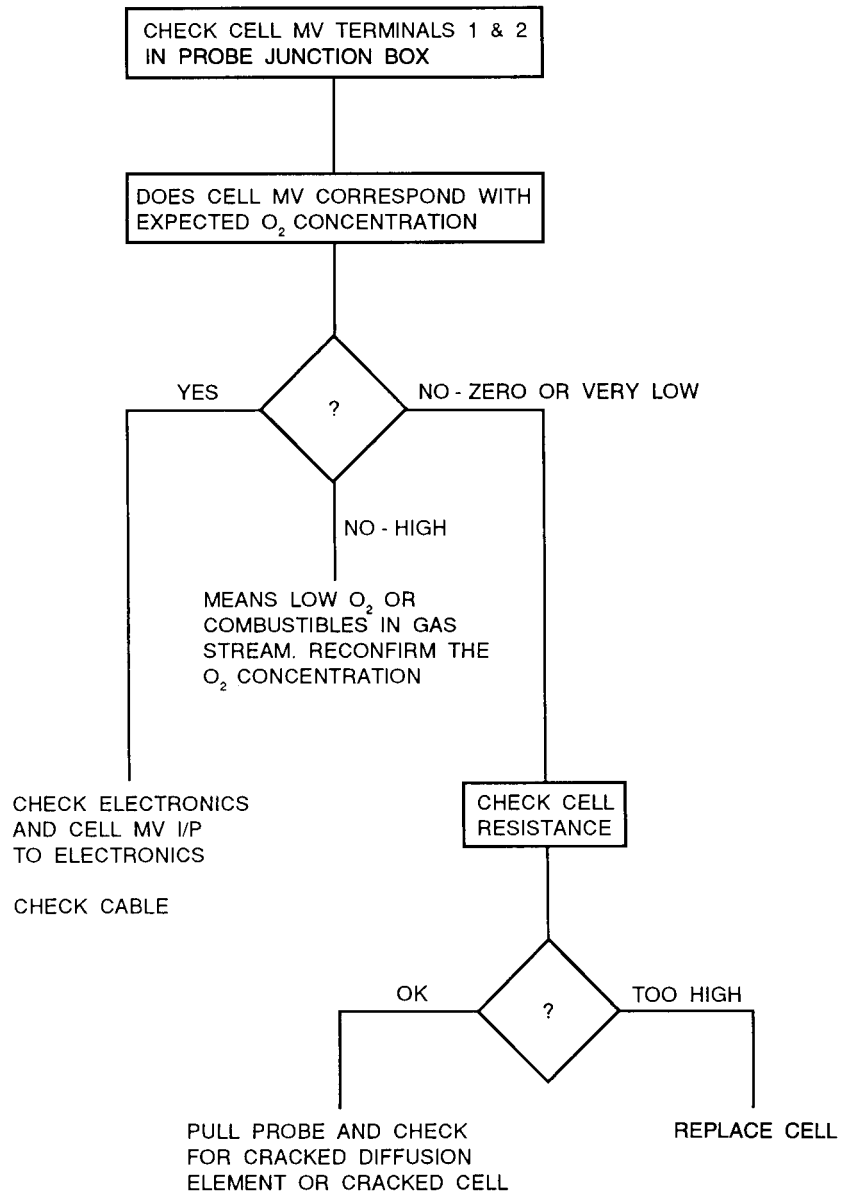

Figure 2-1. Flowchart of Probe Related Problems, #1

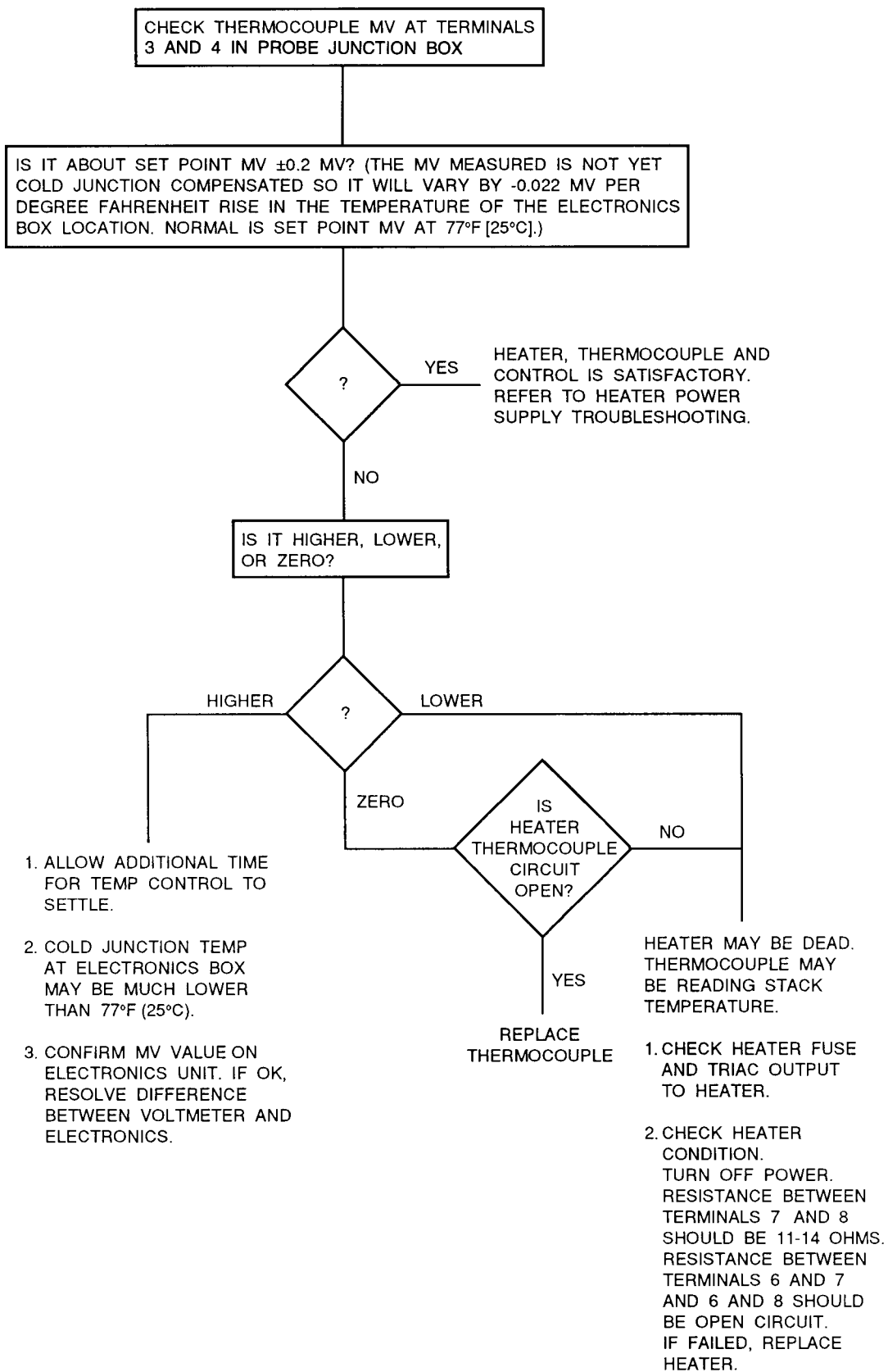

Figure 2-2. Flowchart of Probe Related Problems, #2

SECTION III. SERVICE AND NORMAL MAINTENANCE



Upon completing installation, make sure that the probe is turned on and operating prior to firing up the combustion process. Damage can result from having a cold probe exposed to the process gases.

During outages, and if possible, leave all probes running to prevent condensation and premature aging from thermal cycling.

CAUTION

If the ducts will be washed down during outage, MAKE SURE to power down the probes and remove them from the wash area.

- 3-1. **OVERVIEW.** This section describes routine maintenance of the oxygen analyzer probe. Spare parts referred to are available from Rosemount. Probe disassembly kit 3535B42G01 contains the required spanner and hex wrenches. Refer to Section IV of this appendix for part numbers and ordering information.

WARNING

Install all protective equipment covers and safety ground leads after equipment repair or service. Failure to install covers and ground leads could result in serious injury or death.

- 3-2. **PROBE RECALIBRATION.** The oxygen analyzer system should be calibrated when commissioned. Under normal circumstances the probe will not require frequent calibration. When calibration is required, follow the procedure described in the Instruction Bulletin applicable to your electronics package.

- 3-3. **CELL REPLACEMENT.** This paragraph covers oxygen sensing cell replacement. Do not attempt to replace the cell until all other possibilities for poor performance have been considered. If cell replacement is needed, order cell replacement kit, Table 4-1.

The cell replacement kit contains a cell and flange assembly, corrugated seal, setscrews, socket head cap screws, and anti-seize compound. Items are carefully

packaged to preserve precise surface finishes. Do not remove items from packaging until they are ready to be used. Spanner wrenches and hex wrenches needed for this procedure are part of an available special tools kit, Table 4-1.

WARNING

Wear heat resistant gloves and clothing to remove probe from stack. Normal operating temperatures of diffusor and vee deflector are approximately 600° to 800°F (316° to 427°C). They could cause severe burns.

Disconnect and lock out power before working on any electrical components. There is voltage up to 115 Vac.

CAUTION

Do not remove cell unless it is certain that replacement is needed. Removal may damage cell and platinum pad. Go through complete troubleshooting procedure to make sure cell needs replacement before removing it.

- a. Disconnect and lock out power to electronics. Shut off and disconnect reference air and calibration gas supplies from probe junction box, Figure 3-1. Wearing heat resistant gloves and clothing, remove probe assembly from stack carefully and allow to cool to room temperature. Do not attempt to work on unit until it has cooled to a comfortable working temperature.

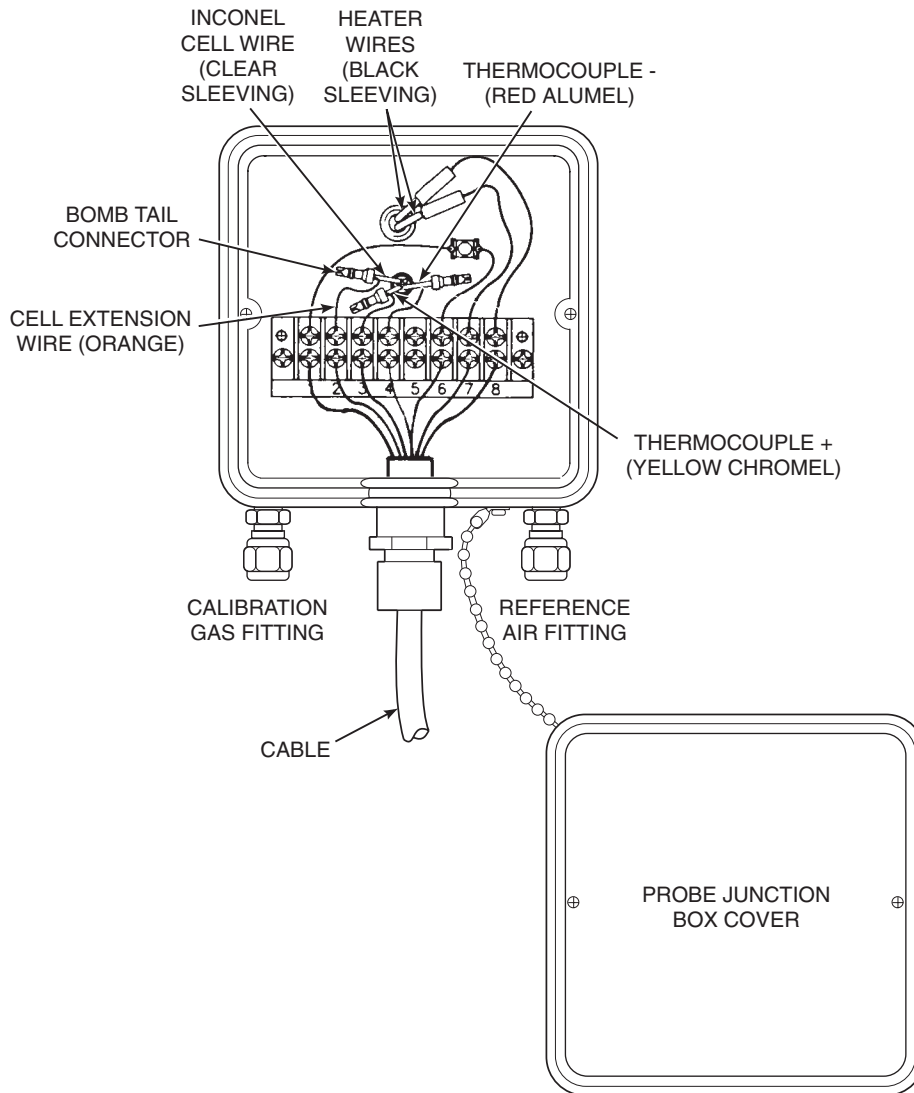

27270019

Figure 3-1. Cell Wiring Connection

- b. If the probe uses the standard diffusion element, use a spanner wrench to remove the diffusion element.
- c. If equipped with the optional ceramic diffusor assembly, remove and discard setscrews, Figure 3-2, and remove vee deflector. Use spanner wrenches from probe disassembly kit, Table 4-1, to turn hub free from retainer. Inspect diffusion element. If damaged, replace element.
- d. Loosen four socket head cap screws from the cell and flange assembly and remove the assembly and the corrugated seal. The cell flange has a

notch which may be used to gently pry the flange away from the probe. Note that the contact pad inside the probe will sometimes fuse to the oxygen sensing cell. If the cell is fused to the contact pad, push the cell assembly back into the probe (against spring pressure), and quickly twist the cell assembly. The cell and contact pad should separate. **If the contact pad stays fused** to the cell, a new contact/thermocouple assembly must be installed. Disconnect the cell and the thermocouple wires at the probe junction box, and withdraw the cell with the wires still attached (see paragraph 3-5).

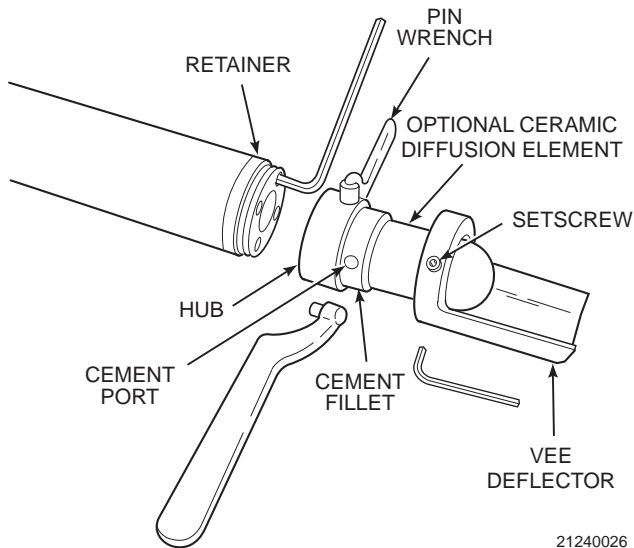

Figure 3-2. Removal of Optional Diffusor and Vee Deflector

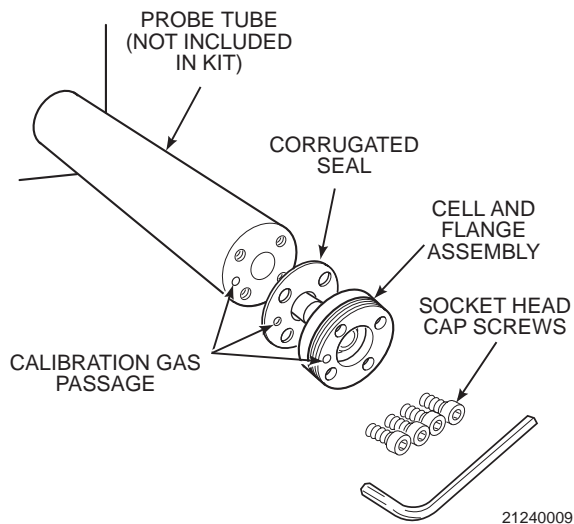

Figure 3-3. Cell Replacement Kit

- e. If contact assembly is damaged, replace contact and thermocouple according to paragraph 3-5, Replacement of Contact and Thermocouple Assembly.
- f. Remove and discard corrugated seal. Clean mating faces of probe tube and retainer. Remove burrs and raised surfaces with block of wood and crocus cloth. Clean threads on retainer and hub.
- g. Rub a small amount of anti-seize on both sides of new corrugated seal.

- h. Assemble cell and flange assembly, corrugated seal, and probe tube. Make sure the calibration tube lines up with the calibration gas passage in each component. Apply a small amount of anti-seize compound to screw threads and use screws to secure assembly. Torque to 55 in-lbs (4 N·m).
- i. Apply anti-seize compound to threads of cell assembly, hub, and setscrews. Reinstall hub on cell assembly. Using pin spanner wrenches, torque to 10 ft-lbs (14 N·m). If applicable, reinstall vee deflector, orienting apex toward gas flow. Secure with setscrews and anti-seize compound. Torque to 25 in-lbs (2.8 N·m).
- j. On systems equipped with an abrasive shield, install dust seal gaskets, with joints 180° apart.
- k. Reinstall probe and gasket on stack flange. If there is an abrasive shield in the stack, make sure dust seal gaskets are in place as they enter 15° reducing cone.
- l. Turn power on to electronics and monitor thermocouple output. It should stabilize at 29.3 ±0.2 mV. Set reference air flow at 2 scfh (56.6 L/hr). After probe stabilizes, calibrate probe per Instruction Bulletin applicable to your electronics package. If new components have been installed, repeat calibration after 24 hours of operation.

3-4. OPTIONAL CERAMIC DIFFUSION ELEMENT REPLACEMENT.

- a. **General.** The diffusion element protects the cell from particles in process gases. It does not normally need to be replaced because the vee deflector protects it from particulate erosion. In severe environments the filter may be broken or subject to excessive erosion. Examine the diffusion element whenever removing the probe for any purpose. Replace if damaged.

Damage to the diffusion element may become apparent during calibration. Compare probe response with previous response. A broken diffusion element will cause a slower response to calibration gas.

Hex wrenches needed to remove setscrews and socket head screws in the following procedure are available as part of a special tool kit, Table 4-1.

WARNING

Wear heat resistant gloves and clothing to remove probe from stack. Normal operating temperatures of diffusor and vee deflector are approximately 600° to 800°F (300° to 425°C). They can cause severe burns.

Disconnect and lock out power before working on any electrical component. There is voltage up to 115 Vac.

CAUTION

It is not necessary to remove the cell unless it is certain that replacement is necessary. Cell cannot be removed for inspection without damaging it. Refer to paragraph 3-3, Cell Replacement.

b. Replacement Procedure.

1. Shut off power to electronics. Disconnect cable conductors and remove cable, Figure 3-1. Shut off and disconnect reference air and calibration gas supplies from probe junction box. Wearing heat resistant gloves and clothing, carefully remove probe assembly from stack and allow to cool to room temperature. Do not attempt to work on unit until it has cooled to a comfortable working temperature.
2. Loosen setscrews, Figure 3-2, using hex wrench from special tools kit, Table 4-1, and remove vee deflector. Inspect setscrews. If damaged, replace with M-6 x 6 stainless setscrews coated with anti-seize compound.
3. On systems equipped with abrasive shield, remove dual dust seal gaskets.
4. Use spanner wrenches from special tools kit, Table 4-1, to turn hub free from retainer.
5. Put hub in vise. Break out old diffusion element with chisel along cement line and 3/8 inch (9.5 mm) pin punch through cement port.
6. Break out remaining diffusion element by tapping lightly around hub with hammer. Clean grooves with pointed tool if necessary.
7. Replace diffusion element, using replacement kit listed in Table 4-1. This consists of a diffusion element, cement, setscrews, anti-seize compound and instructions.
8. Test fit replacement element to be sure seat is clean.

CAUTION

Do not get cement on diffusion element except where it touches the hub. Any cement on ceramic element blocks airflow through element. Wiping wet cement off of ceramic only forces cement into pores.

9. Thoroughly mix cement and insert tip of squeeze bottle into cement port. Tilt bottle and squeeze while simultaneously turning diffusion element into seat. Do not get any cement on upper part of diffusion element. Ensure complete penetration of cement around three grooves in hub. Cement should extrude from opposite hole. Wipe excess material back into holes and wipe top fillet of cement to form a uniform fillet. (A Q-Tip is useful for this.) Clean any excess cement from hub with water.
10. Allow filter to dry at room temperature overnight or 1 to 2 hours at 200°F (93°C).
11. Wipe a heavy layer of anti-seize compound onto the threads and mating surfaces of the diffusion hub and retainer.
12. Assemble retainer and diffusion hub with two pin spanner wrenches. Torque to 10 ft-lbs (14 N•m).
13. On systems equipped with abrasive shield, install dust seal gaskets with joints 180° apart.
14. Reinstall vee deflector, orienting apex toward gas flow. Apply anti-seize compound to setscrews and tighten with hex wrench.

15. Reinstall probe on stack flange.
16. Turn power on to electronics and monitor thermocouple output. It should stabilize at 29.3 ± 0.2 mV. Calibrate probe per Instruction Bulletin applicable to your electronics package.

3-5. REPLACEMENT OF CONTACT AND THERMOCOUPLE ASSEMBLY.

WARNING

Use heat resistant gloves and clothing when removing probe junction box and inner probe assembly. Do not attempt to work on these components until they have cooled to room temperature. Probe components can be as hot as 800°F (427°C). This can cause severe burns.

Disconnect and lock out power before working on any electrical components. There is voltage up to 115 Vac.

- a. Disconnect and lock out power to electronics. Using heat resistant gloves and clothing, remove probe junction box cover. Squeezing tabs on hose clamps, remove hoses from probe junction box, Figure 3-4. Remove four screws in corners of probe junction box. Pull probe junction box and inner probe assembly free from probe tube. Set on bench and allow to cool to room temperature.
- b. Disconnect cell extension wire (orange), thermocouple wire (red alumel), and thermocouple wire (yellow chromel) by cutting bomb tail connections from the terminal strip, Figure 3-1.
- c. Remove two screws, Figure 3-4, lockwashers, and flat washers that connect probe junction box to inner probe assembly. Pull heater, V-strut and backplate assembly away from probe junction box. Inspect all O-rings and insulating gasket; replace if worn or damaged.
- d. Use a pencil to mark locations of spring clip on ceramic rod, Figure 3-5.
- e. Pry or squeeze tabs on spring clips, and pull contact and thermocouple assembly out of probe assembly. Retain spring clips and spring; replace if damaged.

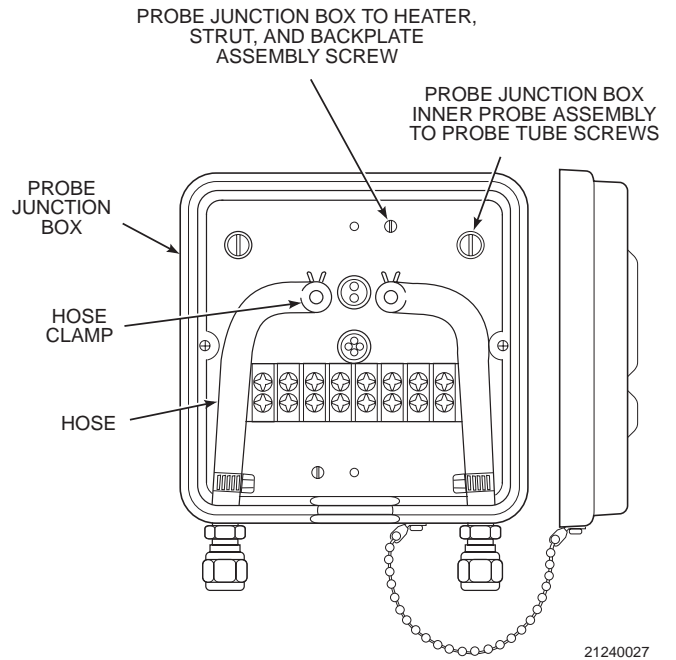

Figure 3-4. Probe Junction Box Mechanical Connections

CAUTION

Be very careful when handling contact and thermocouple assembly. The ceramic rod in this assembly is fragile.

- f. While very carefully handling new contact and thermocouple assembly, lay old assembly next to new one. Transfer pencil marks to new rod.
- g. Note wire lengths of old assembly as an aid for trimming new lengths in step (j). Trimming of wires will not always be necessary. Throw away old contact and thermocouple assembly.

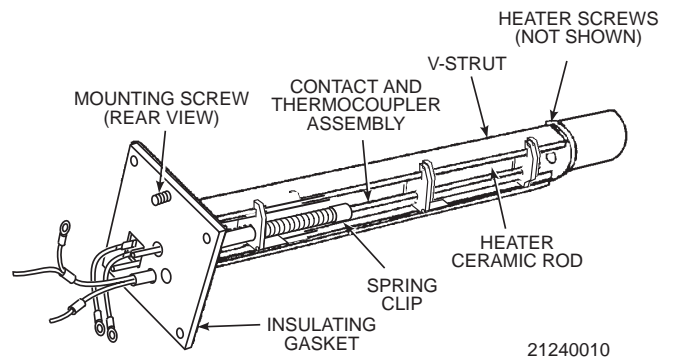

Figure 3-5. Inner Probe Replacement (Heater, V-Strut, and Backplate Assembly)

- h. Carefully guide new contact and thermocouple assembly through V-strut assembly leaf spring (4, Figure 3-6), spring (9), spring clip (10) (held open by squeezing tabs), and tube supports (11, 13) until spring clip reaches pencil mark.
- i. Reinstall insulating gasket on backplate, replace two screws, O-rings, lockwashers and flat washers connecting probe junction box to inner probe assembly.

CAUTION

Do not trim new wiring shorter than existing (old) wiring. Excessive wire trim will prevent connections from being properly made and will require a new replacement kit.

- j. Trim wires, if necessary, as noted in step (g).
- k. Connect color coded wires to proper terminals as shown in Figure 3-1. Rosemount recommends connecting the thermocouple wires directly to the terminal strip. This is because the junction of different metals at the wires and lugs and at the lugs and the terminal strip could act as additional thermocouple junctions. This could produce a voltage that would affect the thermocouple output signal.

Do not bend wires closer than 1/4 inch (6.4 mm) from end of ceramic rod. Dress wires so they do not touch sides of probe junction box.

- l. Slide assembled probe junction box and inner probe assembly into probe tube. To align calibration gas tube with corresponding hole in backplate (A, B, Figure 1-1), insert scribe through hole in backplate and into calibration gas tube. Secure with screws. Reinstall hoses and probe junction box cover.
- m. Power up system. Monitor thermocouple output. It should stabilize at set point mV ± 0.2 mV. Recalibrate probe per Instruction Bulletin applicable to your electronics package.

3-6. REPLACEMENT OF HEATER, V-STRUT AND BACKPLATE ASSEMBLY (Inner Probe Assembly; Includes Contact and Thermocouple Assembly).

WARNING

Use heat resistant gloves and clothing when removing probe junction box and inner probe assembly. Do not attempt to work on these components until they have cooled to room temperature. Probe components can be as hot as 800° (427°C). This can cause severe burns.

Disconnect and lock out power before working on any electrical components. There is voltage up to 115 Vac.

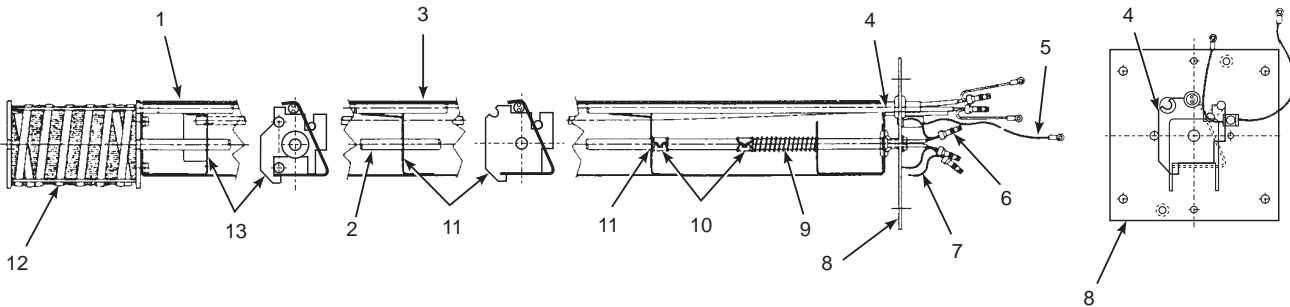

- | | | |
|--------------------------------------|-------------------|--------------------------|
| 1. Heater Ceramic Rod | 5. Ring Lug | 9. Spring |
| 2. Contact and Thermocouple Assembly | 6. Butt Connector | 10. Spring Clip Assembly |
| 3. Strut | 7. Extension Wire | 11. Common Tube Support |
| 4. Leaf Spring | 8. Backplate | 12. Heater |
| | | 13. Short Tube Support |

Figure 3-6. Heater, Strut, and Backplate Assembly (Inner Probe Assembly)

NOTE

This replacement may be done without removing the probe from the duct.

- a. Disconnect and lock out power to electronics. Using heat resistant gloves and clothing, remove probe cover. Squeezing tabs on hose clamps and remove hoses from probe junction box, Figure 3-4. Remove four screws and lockwashers (7, 10, Figure 3-7) that hold probe junction box and inner probe assembly to probe tube. Pull probe junction box and inner probe assembly free from probe tube. Set on bench and allow to cool to room temperature.
- b. Disconnect cell extension wire (orange), thermocouple wire (red alumel), and thermocouple wire (yellow chromel) by cutting bomb tail connections from the terminal strip, Figure 3-1.
- c. Remove two screws, lockwashers, and flat washers that connect probe junction box to inner probe assembly. Remove and discard inner probe assembly (heater, V-strut, and backplate assembly). Replace with new inner probe

assembly. Reinstall screws, lockwashers and flat washers.

- d. Connect color coded wires to proper terminals as shown in Figure 3-1. Rosemount recommends connecting the thermocouple wires directly to the terminal strip. This is because the junction of different metals at the wires and lugs and at the lugs and the terminal strip could act as additional thermocouple junctions. This could produce a voltage that would affect the thermocouple output signal.

Do not bend wires closer than 1/4 inch (6.4 mm) from end of ceramic rod. Dress wires so they do not touch sides of probe junction box.

- e. Slide assembled probe junction box and inner probe assembly into probe tube. To align calibration gas tube with corresponding hole in backplate (A, B, Figure 1-1), insert aligning tool (included in probe disassembly kit, P/N 3535B42G01) through hole in backplate and into calibration gas tube, while sliding the heater strut into the probe tube. Secure with screws. Reinstall hoses and probe junction box cover.

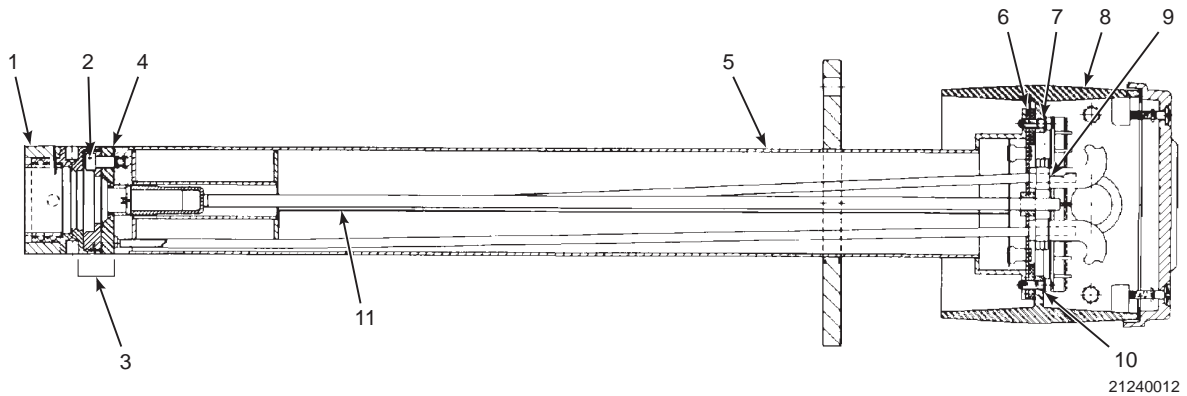

ITEM	DESCRIPTION	SIZE-REFERENCE INFORMATION	ITEM	DESCRIPTION	SIZE-REFERENCE INFORMATION
1	Snubber Diffusion Element		6	Gasket	4.0 in. (102 mm) x 4.0 in. x 0.12 in. (3 mm)
2	Socket Hd Cap Screw	0.25 in.-28 x 0.63 (16 mm)	7	Fillister Hd Screw	8-32 x 0.5 in. (12.7 mm)
3	Cell and Flange Assembly		8	Cover Head Assembly	
4	Corrugated Seal		9	Hose Clamp	
5	Probe Tube Assembly		10	Lockwasher	#8 Split
			11	Heater Strut Assembly	

Figure 3-7. Oxygen Analyzer (Probe), Cross-Sectional View

- f. Power up system. Monitor thermocouple output. It should stabilize at set point ± 0.2 mV. Recalibrate probe per Instruction Bulletin applicable to your electronics package.

3-7. CALIBRATION GAS AND REFERENCE AIR LINES FOR HIGH TEMPERATURE - CORROSIVE ENVIRONMENT OPERATION.

A high temperature, corrosive environment kit is available when the probe is exposed to these types of operating conditions. The kit includes stainless steel tubing and teflon fittings for inside the probe junction box. The kit part number is 4843B93G01.

a. Installation Procedure.

WARNING

Use heat resistant gloves and clothing when removing probe junction box and inner probe assembly. Do not attempt to work on these components until they have cooled to room temperature. Probe components can be as hot as 800°F (427°C). This can cause severe burns.

Disconnect and lock out power before working on any electrical components. There is voltage up to 115 Vac.

1. Disconnect and lock out power to digital electronics. Using heat resistant gloves and clothing, remove probe cover. Squeezing tabs on hose clamps, remove hoses from probe junction box (Figure 3-4).

CAUTION

Do not use sealant when installing the stainless steel tubes. Gas samples may become contaminated

2. First install the stainless steel tubing on the fitting at the bottom of the probe junction box. Install the other end of the stainless steel tube onto the tube going to the probe (Figure 3-8).

NOTE

If abrasive conditions of high ash content and high velocity exist, an abrasive shield is recommended. To balance out the wear on the shield, rotate the shield 90° every time the probe is powered down for service.

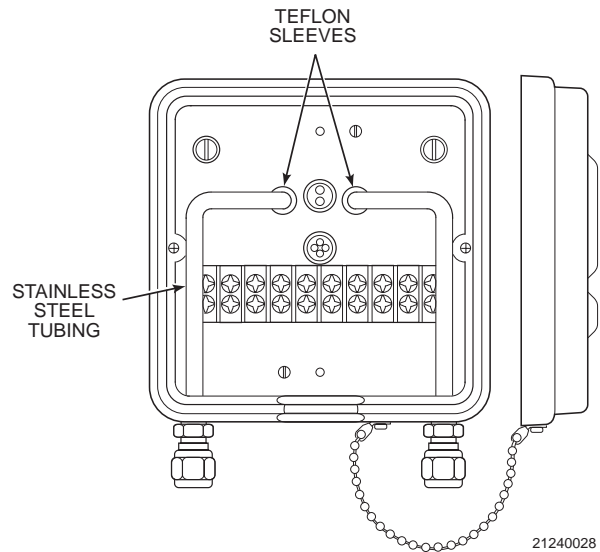

Figure 3-8. High Temperature - Corrosive Environment Kit

SECTION IV. REPLACEMENT PARTS

Table 4-1. Replacement Parts for Probe.

FIGURE and INDEX No.	PART NUMBER	DESCRIPTION
3-5	3D39441G06 ¹	Heater, V-Strut, and Backplate Assembly, 18 in. (45.6 cm)
3-5	3D39441G07 ¹	Heater, V-Strut, and Backplate Assembly, 3 ft (0.9 m)
3-5	3D39441G08 ¹	Heater, V-Strut, and Backplate Assembly, 6 ft (1.8 m)
3-5	3D39441G09 ¹	Heater, V-Strut, and Backplate Assembly, 9 ft (2.7 m)
3-5	3D39441G10 ¹	Heater, V-Strut, and Backplate Assembly, 12 ft (3.6 m)
3-6, 2	3534B56G04 ²	Contact and Thermocouple Assembly, 18 in. (45.6 cm)
3-6, 2	3534B56G05 ²	Contact and Thermocouple Assembly, 3 ft (0.9 m)
3-6, 2	3534B56G06 ²	Contact and Thermocouple Assembly, 6 ft (1.8 m)
3-6, 2	3534B56G07 ²	Contact and Thermocouple Assembly, 9 ft (2.7 m)
3-6, 2	3534B56G08 ²	Contact and Thermocouple Assembly, 12 ft (3.6 m)
1-7	3D39003G01 ³	Abrasive Shield Assembly, 3 ft (0.9 m)
1-7	3D39003G02 ³	Abrasive Shield Assembly, 6 ft (1.8 m)
1-7	3D39003G07 ³	Abrasive Shield Assembly, 9 ft (2.7 m)
1-7	3D39003G08 ³	Abrasive Shield Assembly, 12 ft (3.6 m)
3-3	4847B61G01	Cell Replacement Kit, ANSI, No Lead Wire
3-3	4847B61G02	Cell Replacement Kit, ANSI 18 in. (45.6 cm)
3-3	4847B61G03	Cell Replacement Kit, ANSI 3 ft (0.9 m)
3-3	4847B61G04	Cell Replacement Kit, ANSI 6 ft (1.8 m)
3-3	4847B61G05	Cell Replacement Kit, ANSI 9 ft (2.7 m)
3-3	4847B61G06	Cell Replacement Kit, ANSI 12 ft (3.6 m)
3-3	4847B61G07	Cell Replacement Kit, JIS, No Lead Wire
3-3	4847B61G08	Cell Replacement Kit, JIS 18 in. (45.6 cm)
3-3	4847B61G09	Cell Replacement Kit, JIS 3 ft (0.9 m)
3-3	4847B61G10	Cell Replacement Kit, JIS 6 ft (1.8 m)
3-3	4847B61G11	Cell Replacement Kit, JIS 9 ft (2.7 m)
3-3	4847B61G12	Cell Replacement Kit, JIS 12 ft (3.6 m)
3-3	4847B61G13	Cell Replacement Kit, DIN, No Lead Wire
3-3	4847B61G14	Cell Replacement Kit, DIN 18 in. (45.6 cm)
3-3	4847B61G15	Cell Replacement Kit, DIN 3 ft (0.9 m)
3-3	4847B61G16	Cell Replacement Kit, DIN 6 ft (1.8 m)
3-3	4847B61G17	Cell Replacement Kit, DIN 9 ft (2.7 m)
3-3	4847B61G18	Cell Replacement Kit, DIN 12 ft (3.6 m)
3-3	3535B42G01	Probe Disassembly Kit
1-10	3534B18G01	Diffuser Assembly
1-8	3535B60G01	Diffuser Dust Seal Hub Assembly (For use with Abrasive Shield)
1-10	4841B03G02	Stainless Steel Diffuser Assembly
1-9	3535B63G01	Flame Arrestor Diffuser Dust Seal
1-11	3535B62G01	Flame Arrestor Diffuser
1-4	3534B48G01	Vee Deflector Assembly (For use with standard or dust seal type ceramic diffusers)
3-2	6292A74G02	Diffusion Element Replacement Kit
	1537B70G03	Horizontal and Vertical Brace Clamp Assembly, 9 and 12 foot (2.7 and 3.6 m) probe
3-8	4843B93G01	High Temperature - Corrosive Environment Kit
1-1,2	4843B37G01	Snubber Diffusion Assembly
1-12	4843B38G02	Dust Seal/Snubber Diffusion Assembly

¹Heater, V-strut, and backplate assembly includes contact and thermocouple assembly.

²Contact and thermocouple assembly includes platinum pad and inconel wire.

³Abrasive shield assembly includes accessories necessary for its use and a mounting plate and gasket.

**APPENDIX B, REV. 2.2
HPS 3000
HEATER POWER SUPPLY**

Instruction Bulletin IB-106-300N SERIES

ROSEMOUNT® ANALYTICAL

FISHER-ROSEMOUNT™

HIGHLIGHTS OF CHANGES

Effective February, 1992 Rev. 2

PAGE	SUMMARY
1-1	Figure 1-1. New HPS 3000 Optional Class 1, Division 1, Group B (IP56) Explosion-Proof Enclosure added.
4-1	Figure and Index No. column added to Table 4-1. Replacement Parts for Heater Power Supply.

Effective January, 1995 Rev. 2.1

PAGE	SUMMARY
1-3	Updated Figure 1-3, Heater Power Supply Block Diagram for IB consistency.

Effective January, 1997 Rev. 2.2

PAGE	SUMMARY
1-1	Added warning to read new safety instructions.
1-3	Corrected Table 1-1 specifications list.
2-1	Added protective covers and grounds warning.
3-1	Added protective covers and grounds warning.
4-1	Added expanded fuse description.

TABLE OF CONTENTS

Section		Page
I.	DESCRIPTION	1-1
	1-1. Description	1-1
	1-2. Theory of Operation	1-3
II.	HPS 3000 TROUBLESHOOTING	2-1
	2-1. Overview	2-1
	2-2. HPS 3000 Troubleshooting.....	2-1
III.	SERVICE AND NORMAL MAINTENANCE	3-1
	3-1. Overview	3-1
	3-2. Fuse Replacement.....	3-1
	3-3. Transformer Replacement.....	3-1
	3-4. Mother Board Replacement	3-1
	3-5. Daughter Board Replacement	3-2
IV.	REPLACEMENT PARTS	4-1

LIST OF ILLUSTRATIONS

Figure		Page
1-1.	HPS 3000 Heater Power Supply Field Module.....	1-1
1-2.	Heater Power Supply, Interior.....	1-2
1-3.	Heater Power Supply Block Diagram.....	1-3
2-1.	HPS Troubleshooting Flowchart, #1.....	2-2
2-2.	HPS Troubleshooting Flowchart, #2.....	2-3
2-3.	HPS Troubleshooting Flowchart, #3.....	2-4
3-1.	Heater Power Supply, Exploded View	3-3

SECTION I. DESCRIPTION

WARNING

Read the "Safety instructions for the wiring and installation of this apparatus" at the front of this Instruction Bulletin. Failure to follow the safety instructions could result in serious injury or death.

- 1-1. **DESCRIPTION.** The Rosemount HPS 3000 Heater Power Supply Field Module acts as an interface between probe and electronics, and supplies power to the probe heater. The unit allows the use of probes with a number of different electronics packages.

The HPS is available in a NEMA 4X (IP56) non-hazardous enclosure or an optional Class 1,

Division 1, Group B (IP56) explosion-proof enclosure, Figure 1-1.

The heater power supply, Figure 1-2, consists of a mother board, daughter board, and a transformer for supplying correct voltage to the probe heater. The mother and daughter boards contain terminal strips for connecting probe, electronics, and power supply.

The HPS is jumper configurable for 120, 220, or 240 Vac. For 100 Vac usage, the HPS is factory-supplied with a special transformer. The 100 Vac transformer can also be easily field installed. Refer to paragraph 3-3, Transformer Replacement for installation procedure; refer to Table 4-1, for transformer part numbers.

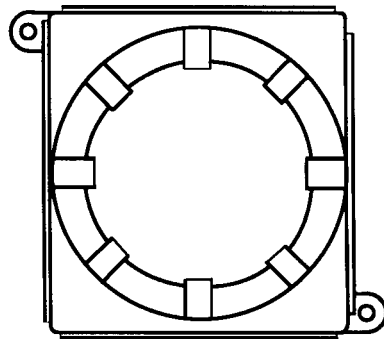

OPTIONAL CLASS 1,
DIVISION 1, GROUP B (IP56)
EXPLOSION-PROOF ENCLOSURE

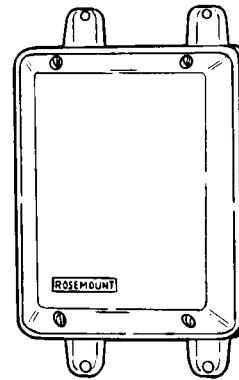

NEMA 4X (IP56)
NON-HAZARDOUS
ENCLOSURE

Figure 1-1. HPS 3000 Heater Power Supply Field Module

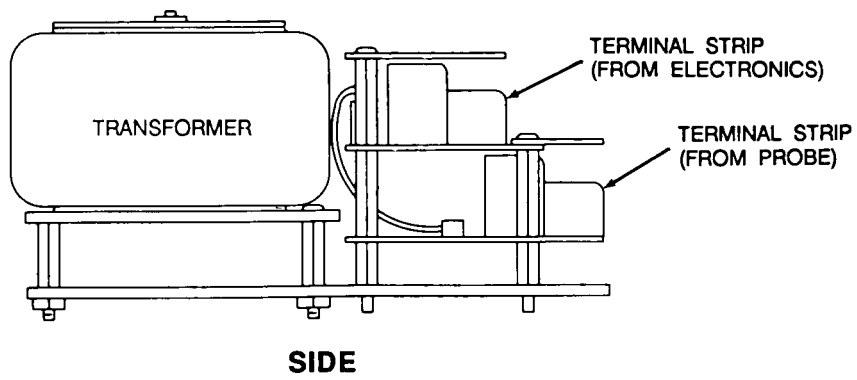
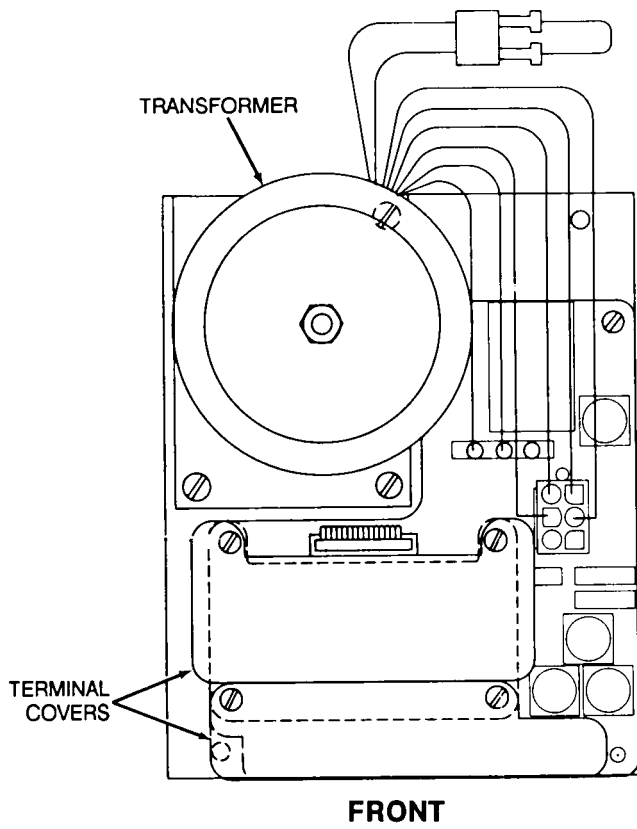

Figure 1-2. Heater Power Supply, Interior

Table 1-1. Specifications for Heater Power Supply.

Environmental Classification.....	NEMA 4X (IP56) Optional - Class 1, Division 1, Group B (IP56)
Electrical Classification	Category II
Humidity Range	95% Relative Humidity
Ambient Temperature Range	-20° to 140°F (-30° to 60°C)
Vibration	5 m/sec ² , 10 to 500 xyz plane
Cabling Distance Between HPS 3000 and Probe.....	Maximum 150 feet (45 m)
Cabling Distance Between HPS 3000 and CRE 3000.....	Maximum 1200 feet (364 m)
Cabling Distance Between HPS 3000 and IFT 3000	Maximum 1200 feet (364 m)
Approximate Shipping Weight.....	12 pounds (5.4 kg)

1-2. THEORY OF OPERATION. The HPS 3000 Heater Power Supply may perform slightly different functions, depending upon which electronics package it is used with. Figure 1-3 shows a functional block diagram of the unit. The HPS contains a transformer for converting line voltage to 44 volts needed to power the probe heater. The relay, Figure 1-3, can be used to remotely turn the probe on or off manually. A triac module is used to turn the heater on or off, depending on probe temperature.

When used with the CRE 3000 Control Room Electronics or IFT 3000 Intelligent Field Transmitter, the HPS uses a cold junction temperature compensation feature. This allows for the use of a less expensive

cable between the HPS and CRE or HPS and IFT. The HPS and electronics package can be located up to 1200 feet (364 m) apart.

The standard cable, between probe and HPS, is thermocouple compensated. This prevents the additional junctions between thermocouple and cable from producing a voltage which would affect the thermocouple output signal. A temperature sensor in the HPS monitors the temperature at the junction and sends a voltage signal to the CRE and IFT. The CRE and IFT uses this signal to compensate the probe thermocouple reading for the temperature at the junction between the compensated and uncompensated cables.

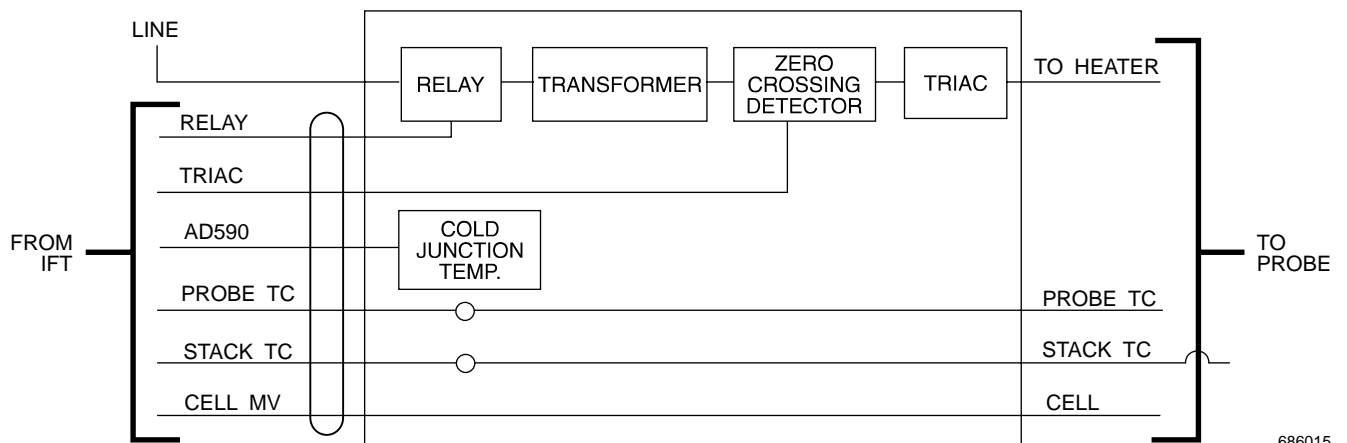

Figure 1-3. Heater Power Supply Block Diagram

In operation, when connected to the CRE 3000 Control Room Electronics, line voltage passes through the relay (when on) and is converted into 44 volts by the transformer. If the probe thermocouple indicates that the probe has dropped below operating temperature, a signal from the CRE triggers the triac. The triac then supplies voltage to the probe heater, warming the cell. Conversely, if the probe thermocouple indicates that the probe heater has reached the upper limit of operating temperature, the CRE deactivates the triac, shutting off power to the heater.

NOTE

When using the HPS 3000 with an existing electronics package, such as Models 218, 218A, 225, or TC200, the electronics will not have the input/output capacity to support all of the functions mentioned in this section. Refer to Instruction Bulletin IB-106-300NE.

SECTION II. HPS 3000 TROUBLESHOOTING

2-1. **OVERVIEW.** The HPS 3000 troubleshooting section describes how to identify and isolate faults which may develop in the HPS 3000 assembly.

2-2. **HPS 3000 TROUBLESHOOTING.** The HPS 3000 troubleshooting may overlap with the probe in use in the system. Faults in either system may cause an error to be displayed in the electronics package. Figures 3-1, 3-2, and 3-3 provide troubleshooting information.

WARNING

Install all protective equipment covers and safety ground leads after troubleshooting. Failure to replace covers and ground leads could result in serious injury or death.

SYMPTOM

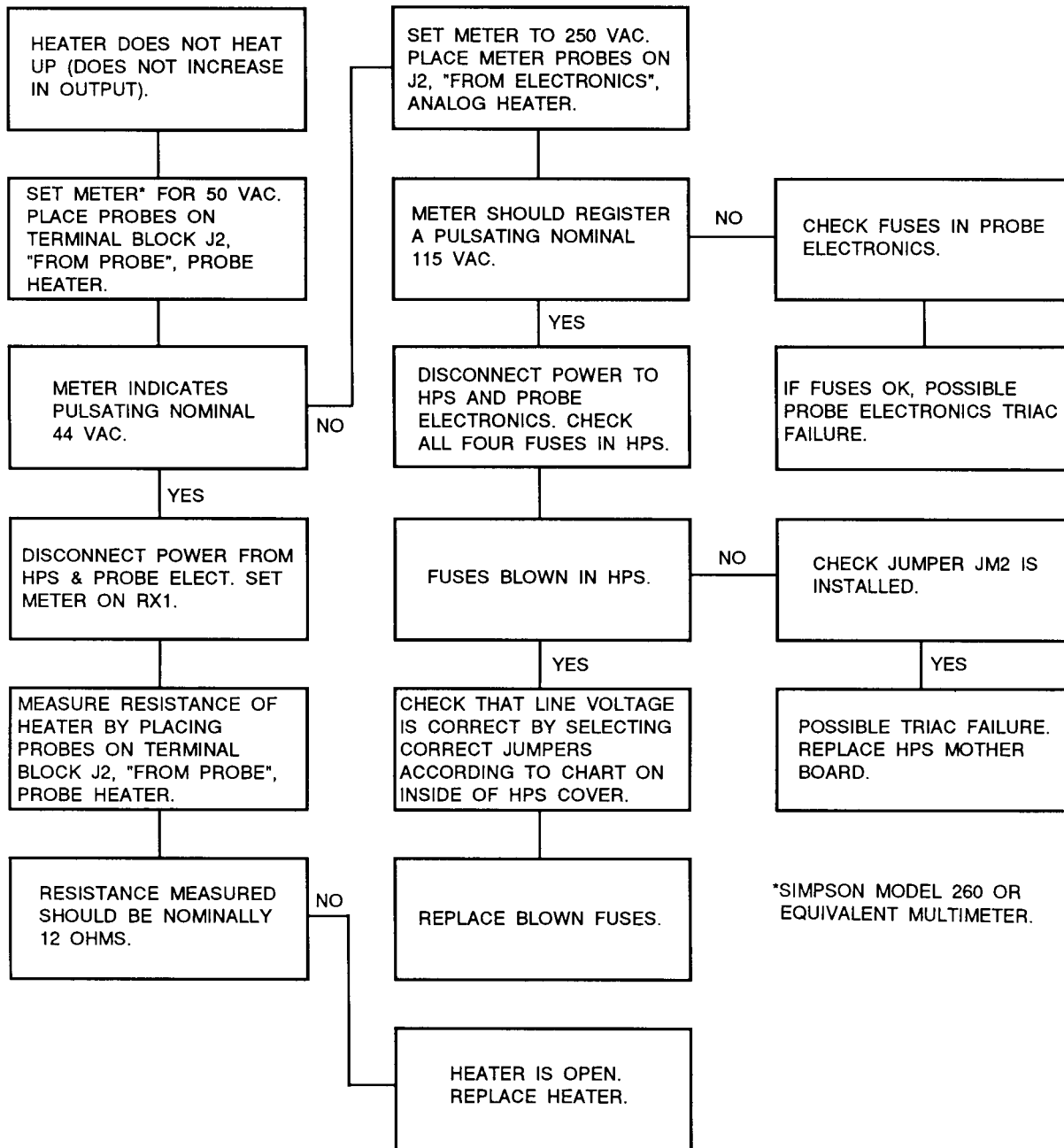
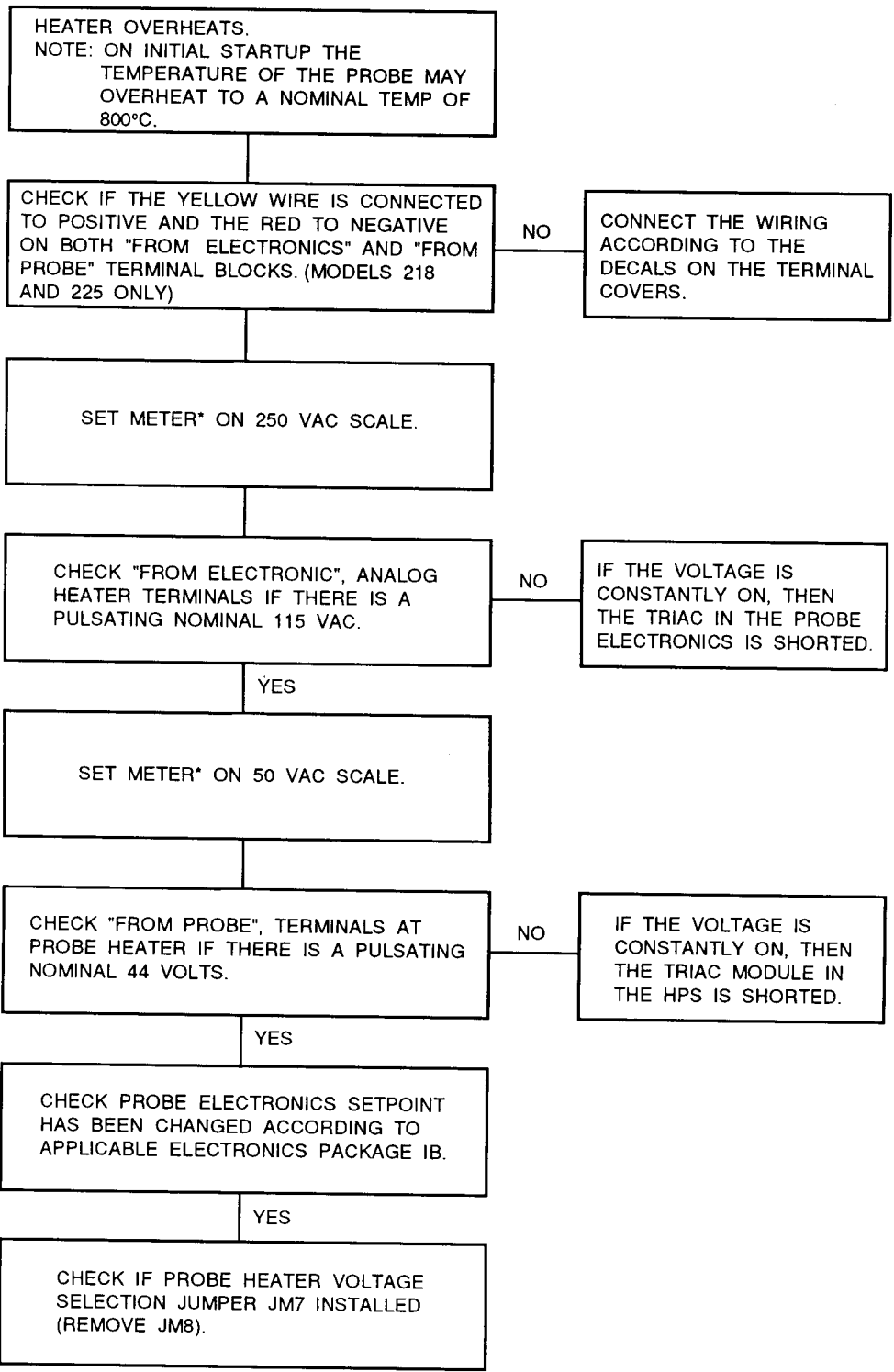

Figure 2-1. HPS Troubleshooting Flowchart, #1

SYMPTOM



*SIMPSON MODEL 260 OR EQUIVALENT MULTIMETER.

Figure 2-2. HPS Troubleshooting Flowchart, #2

SYMPTOM

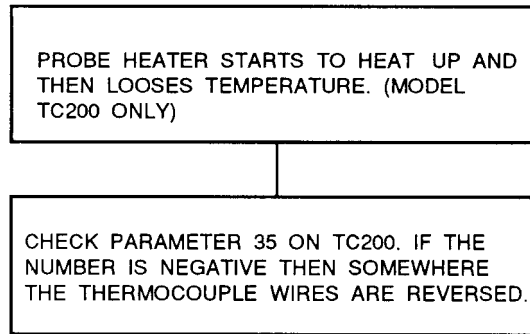

Figure 2-3. HPS Troubleshooting Flowchart, #3

SECTION III. SERVICE AND NORMAL MAINTENANCE

- 3-1. **OVERVIEW.** This section describes service and routine maintenance of the HPS 3000 Heater Power Supply Field Module. Replacement parts referred to are available from Rosemount. Refer to Section IV of this manual for part numbers and ordering information.

WARNING

Install all protective equipment covers and safety ground leads after equipment repair or service. Failure to install covers and ground leads could result in serious injury or death.

- 3-2. **FUSE REPLACEMENT.** The heater power supply mother board (12, Figure 3-1) contains four identical 5 amp fuses. Refer to Table 4-1 for replacement fuse specifications. To check or replace a fuse, simply unscrew the top of the fuseholder with a flat head screwdriver and remove fuse. After checking or replacing a fuse, reinstall fuseholder top.

- 3-3. **TRANSFORMER REPLACEMENT.**

WARNING

Install all protective equipment covers and safety ground leads after equipment repair or service. Failure to install covers and ground leads could result in serious injury or death.

- a. Turn off power to system.
- b. Loosen captive screws retaining HPS cover. Remove cover.
- c. Remove hex nut (25, Figure 3-1) from top of transformer assembly. Remove retaining plate (24) and gasket (22).
- d. Disconnect transformer harness plug from mother board.
- e. Remove old transformer. Place new transformer in position and reconnect harness plug as noted in step d.
- f. Place gasket and retaining plate on transformer.

- g. Tighten hex nut only enough to firmly hold transformer in place.
- h. Reinstall HPS cover.

- 3-4. **MOTHER BOARD REPLACEMENT.**

WARNING

Install all protective equipment covers and safety ground leads after equipment repair or service. Failure to install covers and ground leads could result in serious injury or death.

- a. Turn off power to system.
- b. Loosen captive screws retaining HPS cover. Remove cover.
- c. Remove hex nut (25, Figure 3-1) from top of transformer assembly. Remove retaining plate (24) and gasket (22).
- d. Disconnect transformer harness plug from mother board.
- e. Remove screws on either side of terminal strip covers (2). Remove terminal strip covers (4 and 8).
- f. Unplug ribbon cable from the receptacle on the daughter board (7).
- g. Unscrew stand offs on either side of the daughter board. Remove daughter board (7).
- h. Unscrew four stand offs that supported the daughter board.
- i. Making a note of the location and color of each wire, disconnect wires from terminal strip on mother board.
- j. Remove four screws (9) holding mother board to stand offs (10) on subplate (14).
- k. Remove mother board (12).

- l. Position new mother board on stand offs and reinstall screws removed in step j.
- m. Reconnect wires to terminal strip in positions noted in step i.
- n. Reinstall four stand offs removed in step h. Position daughter board on stand offs and reinstall stand offs removed in step g.
- o. Plug ribbon cable back into receptacle on daughter board. Reinstall terminal covers.
- p. Reinstall transformer, tightening hex nut only enough to hold transformer firmly in position. Reconnect transformer harness plug to mother board.
- q. Reinstall HPS cover.

3-5. DAUGHTER BOARD REPLACEMENT.

WARNING

When turning power off at the HPS, also turn off the respective probe at associated electronics. When service on the HPS is completed, restore power at the HPS and the associated electronics.

- a. Turn off power to system.
- b. Loosen captive screws retaining HPS cover. Remove cover.
- c. Remove screws on either side of terminal strip covers (2, Figure 3-1). Remove terminal strip covers (4 and 8).
- d. Making a note of the location and color of each wire, disconnect wires from the terminal strip on the daughter board (7).
- e. Unplug ribbon cable from receptacle on daughter board.
- f. Unscrew two stand offs from daughter board. Remove daughter board (7).
- g. Position new daughter board on four stand offs on mother board. Reinstall the stand offs removed in step f.
- h. Plug ribbon cable into receptacle on daughter board.
- i. Reconnect wires to terminal strip in positions noted in step d. Reinstall terminal covers.
- j. Reinstall HPS cover.

LEGEND FOR FIGURE 3-1.

- | | |
|--------------------|---------------------|
| 1. Enclosure Cover | 14. Subplate |
| 2. Screw | 15. Enclosure Box |
| 3. Lockwasher | 16. Lockwasher |
| 4. Terminal Cover | 17. Stand Off |
| 5. Stand Off | 18. Screw |
| 6. Lockwasher | 19. Lockwasher |
| 7. Daughter Board | 20. Mounting Plate |
| 8. Terminal Cover | 21. Screw |
| 9. Screw | 22. Gasket |
| 10. Stand Off | 23. Transformer |
| 11. Hex Nut | 24. Retaining Plate |
| 12. Mother Board | 25. Hex Nut |
| 13. Fuse | |

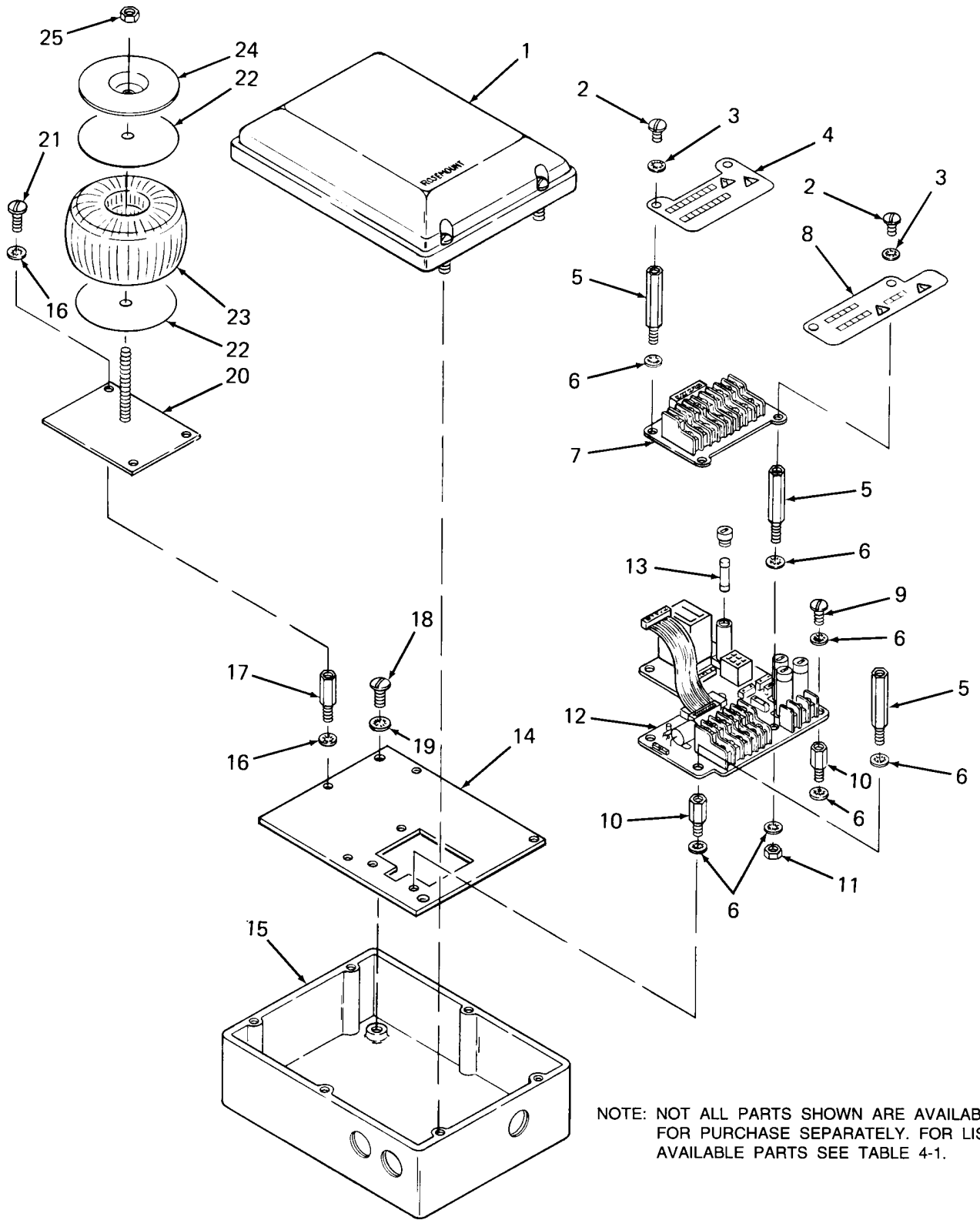

NOTE: NOT ALL PARTS SHOWN ARE AVAILABLE FOR PURCHASE SEPARATELY. FOR LIST OF AVAILABLE PARTS SEE TABLE 4-1.

Figure 3-1. Heater Power Supply, Exploded View

SECTION IV. REPLACEMENT PARTS

Table 4-1. Replacement Parts for Heater Power Supply.

FIGURE and INDEX NO.	PART NUMBER	DESCRIPTION
1-1	3D39129G01	Non-Hazardous HPS (120 Vac)
1-1	3D39129G02	Non-Hazardous HPS (100 Vac)
1-1	3D39129G03	Non-Hazardous HPS (220, 240 Vac)
1-1	1U05667G01	Explosion-Proof HPS (120 Vac)
1-1	1U05667G02	Explosion-Proof HPS (100 Vac)
1-1	1U05667G03	Explosion-Proof HPS (220, 240 Vac)
3-1, 13	1L01293H02	Fuse, 5A @ 250 Vac, anti-surge, case size; 5 x 20 mm, type T to IEC127, Schurter
3-1, 12	3D39080G02	Mother Board
3-1, 7	3D39078G01	Daughter Board
3-1, 23	1M02961G01	Transformer (120, 220, 240 Vac)
3-1, 23	1M02961G02	Transformer (100 Vac)

